



# Hydraulically-Driven Pressure Washer

Models 1802C, 1803C, 1804C, 1805C, 1806C, 1807C, 1824C, 1825C, 1826C and 1827C

Form L-0560PW  
02/10

## Installation, Operation, Repair, and Parts Manual

### Description

#### Hydraulically-Driven Pressure Washers



Model Number	Max. GPM	Max. PSI	Hydraulic Motor Requirements		Description	Estimated Weight Ea.
			GPM	PSI		
1803C	3.0	1000	5.0	1300	Forged Brass Head Triplex Pump with hydraulic motor, adjustable unloader, gauge, 1/2" NPT input, 3/8" quick disconnect output	28 lbs.
1805C	3.0	1500	8.0	1900	Forged Brass Head Triplex Pumps with hydraulic motor, chemical injector, adjustable unloader, gauge, 3/4" GH input, 3/8" quick disconnect output	26 lbs.
1807C	3.0	2000	11.0	1300		26 lbs.
1825C	4.0	1500	8.5	2000		33 lbs.
1827C	4.0	2000	8.5	2000		33 lbs.

#### Hydraulically-Driven Pressure Washers with Hose and Gun Assembly



Model Number	Max. GPM	Max. PSI	Hydraulic Motor Requirements		Description	Estimated Weight Ea.
			GPM	PSI		
1802C	3.0	1000	5.0	1300	Forged Brass Head Triplex Pump with hydraulic motor, adjustable unloader, gauge, 1/2" NPT input, 3/8" quick disconnect output, and 50 ft. hose and gun assembly	38 lbs.
1804C	3.0	1500	8.0	1900	Forged Brass Head Triplex Pumps with hydraulic motor, chemical injector, adjustable unloader, gauge 3/4" GH input, 3/8" quick disconnect output, and 50 ft. hose and gun assembly	41 lbs.
1806C	3.0	2000	11.0	1300		26 lbs.
1824C	4.0	1500	8.5	2000		49 lbs.
1826C	4.0	2000	8.5	2000		49 lbs.

### General Safety Information

#### NOTE

Notes are used to notify of installation, operation, or maintenance information that is important but not safety related.

#### CAUTION

Caution is used to indicate the presence of a hazard, which will or can cause minor injury or property damage if the notice is ignored.

#### DANGER

Do not pump flammable or explosive fluids such as gasoline, fuel oil, kerosene, etc. Do not use in explosive atmospheres unless the Pump is properly grounded and the proper drive is used. The Pump should only be used with liquids compatible with the Pump materials. Failure to follow this notice can result in severe personal injury and/or property damage and will void the product warranty.

#### WARNING

Warning denotes that a potential hazard exists and indicates procedures that must be followed exactly to either eliminate or reduce the hazard, and to avoid serious personal injury, or prevent future safety problems with the product.

#### DANGER

Danger is used to indicate the presence of a hazard that will result in severe personal injury, death, or property damage if the notice is ignored.

#### WARNING

The sound pressure level of the Pump may exceed 80dBA. Observe all safety precautions when operating the Pump within close proximity for extended periods by wearing hearing protectors. Extended exposure to elevated sound levels will result in permanent loss of hearing acuteness, tinnitus, tiredness, stress, and other effects such as loss of balance and awareness.

**⚠ CAUTION**

Do not pump at pressures higher than the maximum recommended pressure.

Operate the Pump between a temperature range of 45° to 140° F [7° to 60° C].

Make certain that the power source conforms to the requirements of your equipment.

Provide adequate protection in guarding around the moving parts such as shafts and pulleys.

Disconnect the power before servicing.

Release all pressure within the system before servicing any component.

Drain all liquids from the system before servicing.

**⚠ CAUTION**

Secure the discharge line before starting the pump. An unsecured discharge line may whip, resulting in personal injury and/or property damage.

Check all hoses for weak or worn condition before each use. Make certain that all connections are tight and secure.

Periodically inspect the pump and the system components. Perform routine maintenance as required.

Use only pipe, hose, and hose fittings rated for maximum rated pressure of the pump or the pressure at which the pressure relief valve is set at. Do not use used pipe.

Do not use these pumps for pumping water or other liquids for human or animal consumption.

## Hazardous Substance Alert

**⚠ CAUTION**

Always drain and flush the pump before servicing.

Always drain and flush the pump prior to returning the Pump to Hypro for repair.

Never store a pump containing hazardous materials.

Prior to returning a pump for service or repair, drain all liquids and flush the pump with a neutralizing fluid; then, drain the pump again, and attach a tag or written notice certifying that this procedure has been done.

It is illegal to ship or transport any hazardous chemical without United States Environmental Protection Agency licensing.

**⚠ DANGER**

Never use your hand to check the condition of hydraulic lines or hoses. If hydraulic fluid penetrates the skin, get medical help immediately. Failure to get proper medical help may result in loss of limb or life. The safest way to check hydraulic lines or hoses is by holding a piece of cardboard next to the hydraulic line or hose.

## Installation Requirements

Hypro's Hydraulically-Driven Pressure Washer can be installed on tractors with Closed Center and Load Sensing Hydraulic Systems, or on Custom Open Center Hydraulic Systems.

The required inlet conditions for the water pump can vary from the flooded suction of a water tank to pressure from a city water supply. The water supply must be capable of supplying more than 4.0 gpm of water flow to meet the pump requirements.

The pump comes equipped with an unloader valve and bypass system rated for 2000 psi. When the trigger of the gun is in the OFF position, the unloader allows water to recirculate back through the pump. A thermal relief valve is included to keep the pump from overheating when it is in the bypass mode with the gun trigger in the OFF position. For long pump life, do not allow the pump to run more than five minutes with the gun trigger in the OFF position.

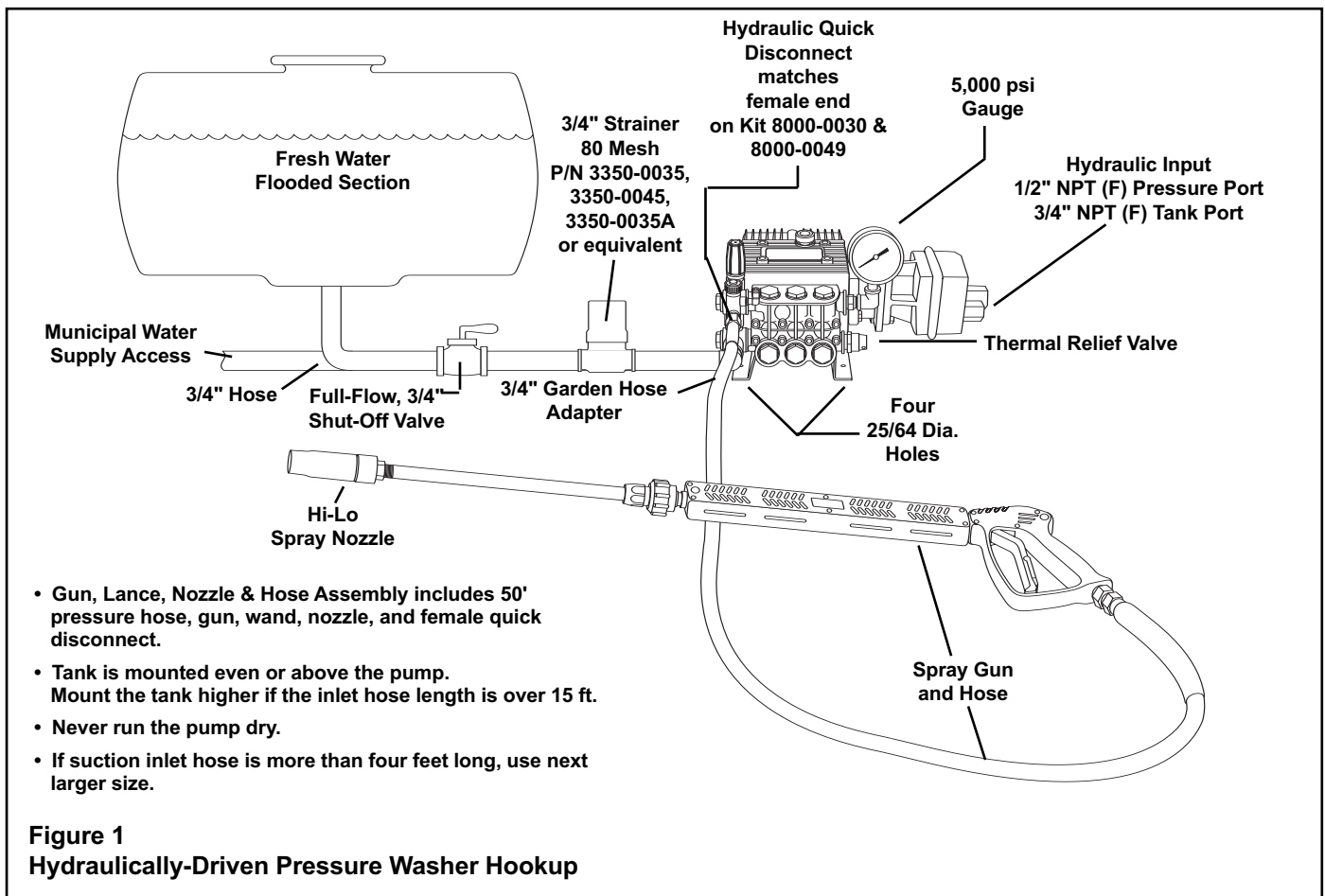

### Unloader Valve Instructions

#### **CAUTION**

The Unloader is factory set to a maximum of 2000 psi [138 BAR]. Do not tamper with the Unloader Valve settings or with the Locking Ring. Hydraulic System damage may result if the Unloader is adjusted outside the range of 2000 psi [138 BAR].

The Unloader Valve is factory tested and preset to 2000 psi [138 BAR]. Adjustment is necessary only if the unloader is not functioning properly.

1. For priming, the Spray Gun and Hose Assembly (Kit 8000-0030) should be detached from the pump at the Quick Disconnect (See Figure 1).
2. Start the Pump and run it until it is fully primed, with water flowing freely out of the Quick Disconnect. Then, stop the Pump and reattach the Spray Gun and Hose Assembly at the Quick Disconnect (See Figure 1).
3. Pull the Gun Trigger, restart the Pump, and observe the pressure. The Hydraulic System and/or Bleeder Bypass Screw may require adjustment to obtain the proper pressure of 2,000 psi [138 BAR] (Refer Hydraulic System Operation for further information).
4. Open and close the Pressure Wash Gun several times to check the unloading pressure and Unloader Valve function.

5. The standard Pressure Washer is equipped with an adjustable cleaning angle nozzle. The cleaning angle may be varied throughout its range by rotating the black outer body clockwise (CW) or counterclockwise (CCW).
6. Your Pressure Washer is equipped with the optional Detergent Injection System. The nozzle must be set in Low Pressure Mode to activate the injector and draw soap. For rinsing, the nozzle should be set in High Pressure Mode. Pushing the black nozzle body forward places the nozzle in the Low Pressure Mode. Pulling the black nozzle body back places the nozzle in the High Pressure Mode.

### Before Starting Up

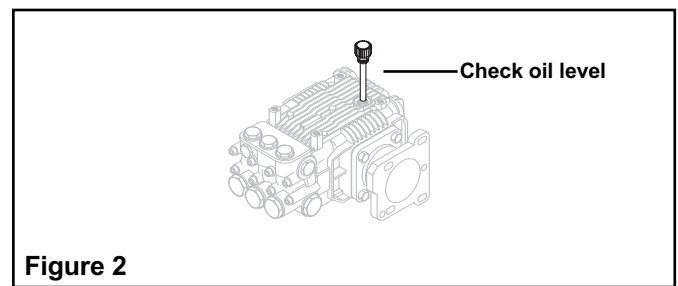

Check that the oil is at the correct level using the Dipstick, and topping off if necessary (See Figure 2). Use Hypro Oil (part no. 2160-0038). Hypro oil is specially formulated, high grade, non-detergent, SAE 30 weight oil designed to prolong Pump life.

Change the oil after 40 hours of break-in operation. Thereafter, change the oil every year or 500 hours, whichever comes first.

### Care of the Pump

After each use, flush the pump with a neutralizing solution for the liquid pumped. Follow this with a clear water rinse. For storage under freezing conditions, flush

the pump with a 50/50 solution of automotive-type antifreeze and water.

### Bypass Operation

During Bypass Operation (when water is diverted back to the pump inlet side) a temperature rise occurs. A Thermal Relief Valve is provided to maintain the maximum water temperature at 145° F [63° C].

## Hydraulic System Operation

### Hydraulic Systems

There are three types of Hydraulic Systems: Open center, Closed Center (Pressure Compensated), and Closed Center Load Sensing (Flow and Pressure Compensated).

### Open Center Systems

In an Open Center System, the hydraulic pump puts out a constant flow. If the Pump puts out more than the Motor can use, a portion of the oil must be bypassed around the Motor. The Bleeder Bypass Screw allows the fluid to bypass around the Motor. When the oil is bypassed around a loop and does no work, the energy put into it by the Pump turns into heat. Therefore, this should only be used on smaller Open Center Systems where the amount of oil that must be bypassed is minimal.

### Closed Center (Pressure Compensated) Systems

Closed Center (Pressure Compensated) Systems have a Variable Displacement Pump that will deliver flow at the necessary rate to maintain a specified pressure. The Flow Control Valve should be installed at the Motor Inlet to control the flow according to the Model requirements.

### Closed Center Load Sensing Systems (Flow and Pressure Compensating)

The Closed Center Flow Compensated System is a variation of the Pressure Compensated System, designed primarily for more efficient operation and the generation of less heat. It works on the principle of maintaining a constant pressure drop from the pump to the working port of the Selector Valve. Any variation in demand at the Motor will cause a change in flow. The system senses this change in flow due to the change in pressure drop across the Valve and causes the pump to compensate by varying the Pump flow

#### ⚠ CAUTION

**Do not bypass oil. Use a Flow Control at the Motor Inlet to control the flow and speed of the motor.**

### Hydraulic Oil

The specifications for the Hydraulic-Driven Pressure Washer where compiled using Mobil DTE-26 hydraulic oil at a temperature of 140° F [60° C]. Using other type of oil and different temperatures will result in different flow requirements to replicate these Pressure Washer performance specifications. These specifications are a guide for initial start-up.

## Pump Repair Instructions

### Plunger Replacement.

1. Using a metric allen wrench, remove the Socket Head Cap Screws securing the Pump Head to the Pump Body (See Figure 3).
2. While turning the Crankshaft, use two screwdrivers to carefully pry between the Pump Head and Pump Body to remove the Pump Head (See Figure 4).
3. Remove the plunger Retaining Nut and the Plunger Retaining Nut Washer (See Figures 5).
4. Slide the Plungers off the Piston Guides (See Figure 5).
5. Remove and discard the O-rings (See Figure 5).
6. Remove the Slinger Ring (See Figure 5).

Remove  
Socket Head Cap  
Screws

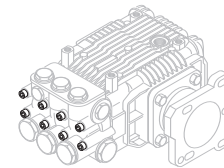

Figure 3

While turning the  
crankshaft, use  
screwdrivers to pry  
the pump head off.

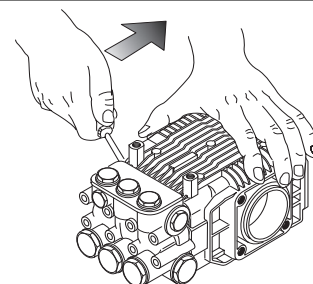

Figure 4

**NOTE**

Apply a thin film of oil to the new O-rings and Plungers before installing them.

7. Inspect the Plungers for cracking and replace them if damaged installing new O-rings and Slinger Rings at the same time.
8. Install the Plunger Retaining Nut Washers: then, apply a drop of blue thread locking compound to the threads of the Plunger Retaining Nuts and install them.
9. Tighten the Plunger Retaining Nuts to 88 in. lbs. [9.8 Nm] torque (See Figure 5).

**NOTE**

If you are replacing the Packings, proceed with Packing Replacement.

10. Lubricate the Plungers and install the Pump Head onto the Plungers: then, push the Pump Head against the Pump Body.
11. Install the Socket Head Cap Screws removed in Step 1; then tighten them as shown in Figure 6 to 88 in. lbs. [9.8 Nm] torque.

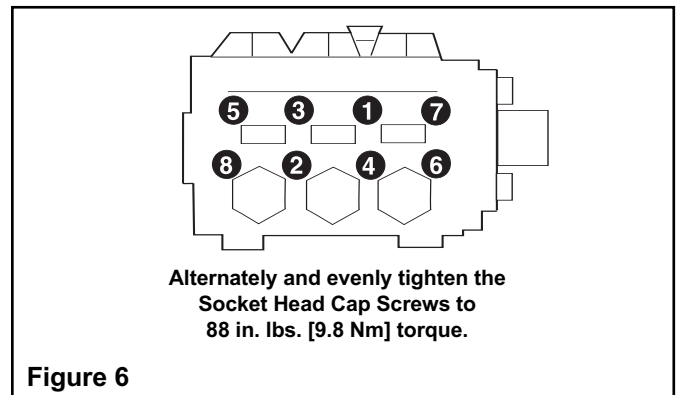
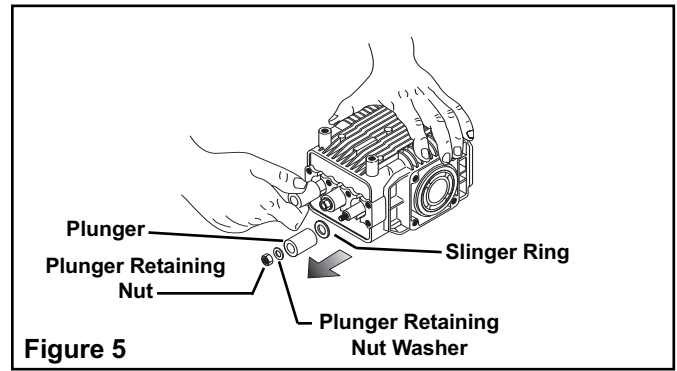

**Packing Replacement**

Water leakage between the pump head and pump body indicates the plunger packings require replacement.

1. Using a metric allen wrench, remove the socket head Cap Screws securing the pump head to the pump body (See Figure 3).
2. While turning the crankshaft, use two screwdrivers to carefully pry between the pump head and pump body to remove the pump head (See Figure 4).
3. Using Extractor Pliers, remove the Seal Retainers and Seals (See Figure 7).
4. Using a small blade knife, remove the Seals from the Seal Retainers.
5. Lightly lubricate and install new seal kit items in the order shown in Figures 8 and 9.
6. Lightly lubricate the plungers and install the pump head onto the plungers: then push the pump head against the pump body.
7. Install the socket head Cap Screws removed in Step 1; then tighten them as shown in Figure 6 to 88 in. lbs. [9.8 Nm] torque.

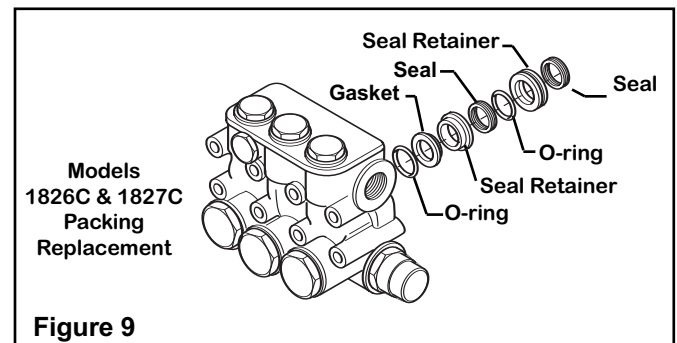
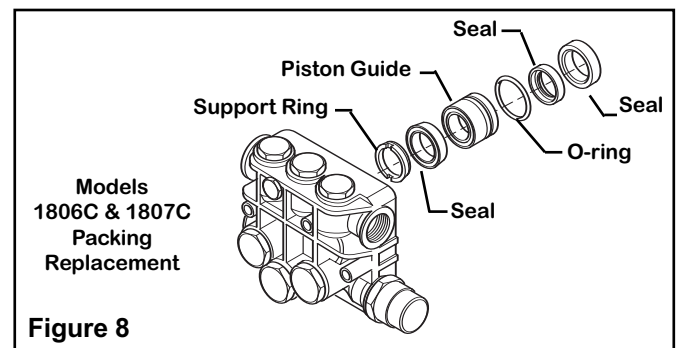
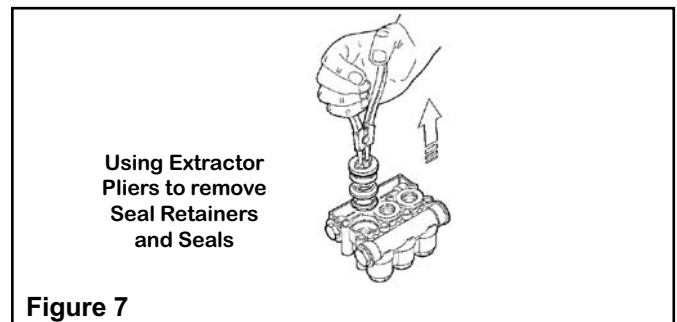

### Valve Replacement

Erratic or low-pressure operation may be the result of debris in the Valves or Worn Poppets and/or Seats.

1. Remove the Plugs; then using needle nosed pliers, remove the Valves (See Figure 10).
2. Remove and discard the old O-ring (See Figure 10).
3. Inspect the Valves for signs of debris and/or wear. If worn or damaged, replace the Valves and install new O-rings (See Figure 10).
4. Install the Plugs and tighten them to 25 ft. lbs. [33.9 Nm] torque (See Figure 10).

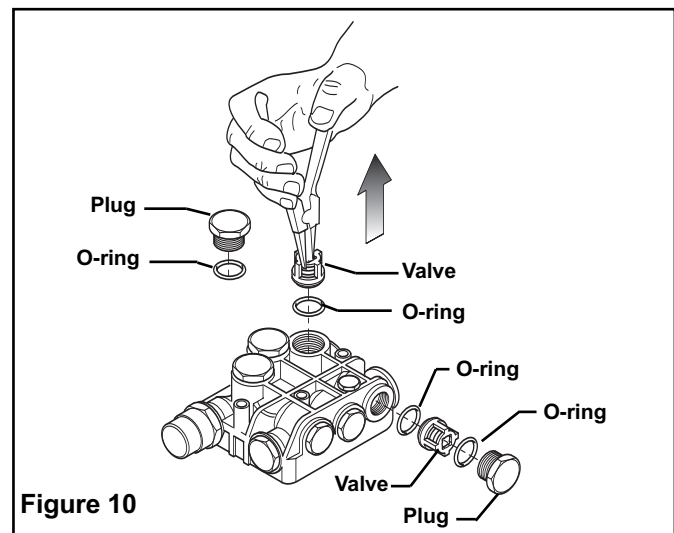

## Hydraulic Motor Repair Instructions

### Disassembly and Repair of the Hydraulic Motor

#### **NOTE**

The work area and motor should be as clean as possible to prevent contamination of parts.

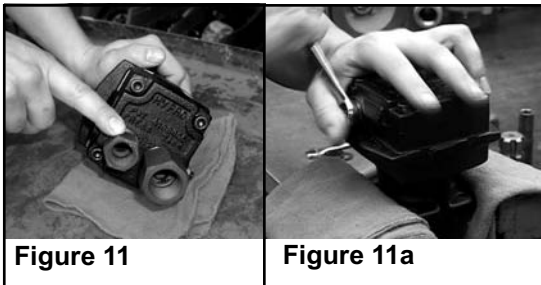

1. Remove the motor from the pump assembly and place Hydraulic Motor in vise.
2. Remove Tank Port Adapter and Pressure Port Adapter with large crescent wrench or 1-1/16" and 1-3/8" box end wrench (See Figure 11).
3. Using a 9/16" box end wrench, loosen the nut on the Bypass Adjusting Screw (See Figure 11a).
4. Using a small screwdriver, remove the Bypass Adjusting Screw from the Motor. (This will remove the Screw, Nut, Washer and Thread-Seal Gasket.)
5. Using a 1/4" Allen wrench, remove the Socket Head Cap Screws from the Motor End Plate (See Figure 11).
6. If Motor End Plate will not lift off easily, use a small screwdriver to carefully pry apart the boss portion of the End Plate and Gerotor Housing until free (See Figure 12). If Gerotor Housing will not lift off easily, carefully pry apart the boss area between the Gerotor Housing and the Motor Body. (It may be necessary to alternate sides when prying apart Motor sections.)



7. Remove both parts of the Gerotor.
8. Remove the Roll Pin from the Shaft.
9. Remove the o-ring from the Motor End Plate and Body with a flat instrument such as a knife blade.
10. Inspect Motor End Plate, Body and Gerotor Housing for wear and/or gouging. If gouging has occurred in both the Motor End Plate and Body, the motor is not repairable. If gouging has occurred in the Motor End Plate, Body or Gerotor Housing, the part that is worn must be replaced. If Gerotor Housing is damaged, Gerotor parts must also be replaced.

### To Remove the Shaft Assembly from the Motor Body

#### **⚠ WARNING**

**Special attention should be exercised when working with retaining rings. Always wear safety goggles when working with spring or tension loaded fasteners or devices.**

1. Using the large retaining ring pliers, remove the Retaining Ring next to the Ball Bearing in the Motor Body.

**NOTE**

If bearing is binding against the retaining ring so that it cannot easily be removed, place the motor body (threaded portion of the shaft up) on arbor press. Using a piece of un-threaded metal pipe (1" dia. x 4" high [254. mm x 101.6 mm high]), slide over the shaft and gently press down with the arbor press just enough to relieve the pressure on the retaining ring.

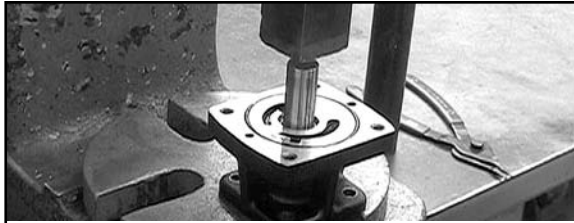

Figure 13

- Place body in position on arbor press. Threaded portion of the Shaft should be inside the fixture. Press out shaft assembly with arbor press (See Figure 13).

**Hydraulic Motor Shaft Disassembly and Repair**

- Remove Large Retaining Ring from Shaft with a screwdriver. Remove Thrust Bearing Assembly from Shaft (includes the Thrust Bearing and two Thrust Bearing Races) and the Seal Spacer.
- Remove the Small Retaining Ring next to the Shaft Ball Bearing.
- To remove the Bearing from the shaft, place the shaft (threaded end up) in the arbor press fixture. Place the two support bars provided in the repair kit opposite each other and between the seal on the shaft and the arbor press fixture. Using an arbor press, press the shaft through the Bearing, Seal Spacer and Seal (See Figure 14).
- Inspect the sealing area of the shaft for wear. Inspect other Shaft Assembly Components for wear and replace if necessary.

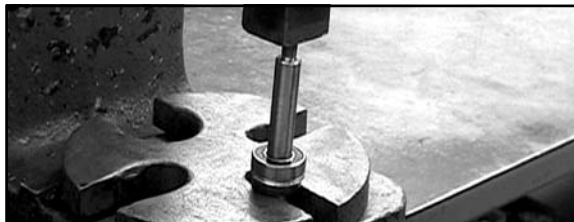

Figure 14

- While motor is completely disassembled, clean all parts in a solvent bath.

**Assembly Instruction for New Seal-Type Motors**

**New Seal Type**

Case-drain casting boss is present (with or without case drain port) only on motors manufactured with "new" type hydraulic seal.

Case-drain boss with or without machined feature

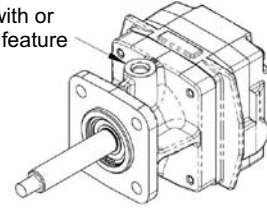

- To assemble the seal cartridge, remove the old seal from the cartridge by pressing it out. The cartridge is reused by assembling the new seal into cartridge, ensuring the new seal is pressed in with the lip seal on the opposite side as shown in Fig.1.

**Note:** To prevent damage to the seal lip extending out, use seal spacer as shown to guard lip during assembly.

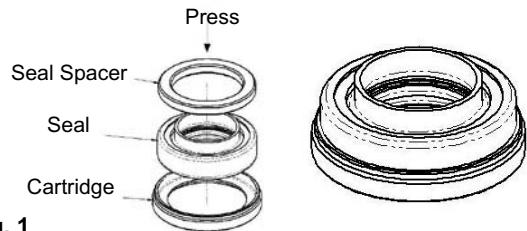

Fig. 1

- Install the large retaining ring onto large diameter end of shaft.
  - From the small, threaded end of the shaft, install the following parts in this order: thrust bearing race, thrust bearing, 2nd thrust bearing race.
- Note:** The thrust bearing and races should not be reused if they are showing any signs of wear.
- Install new type seal spacer (looks like a thick washer, approx .130 inch thick.)
  - Before installing the new seal, its lip must be expanded to fit on the shaft. With the seal lip facing out, slide the seal over the threaded end of the shaft and gently push the seal onto the raised area of the shaft. Do not push the seal past the large retaining ring groove on the shaft.
  - Once the seal has been expanded, remove the seal from the shaft.
  - Install seal cartridge assembly: With seal lip facing the large end of the shaft, slide the seal cartridge assembly over the threaded end of the shaft and gently push into the raised area of the shaft. Align the seal lip to enter the center diameter of the seal spacer and push until seal body touches seal spacer.

**Note:** If the seal lip is longer than the seal spacer's width, please stop the assembly and review parts being used.

- Assemble two o-rings on the outside body of the new seal cartridge assembly as shown in Fig 2. Install o-rings one at a time and do not roll over each other.

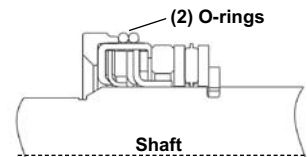

Fig. 2

- Finished shaft sub-assembly should look like this:



- Do not press, but place the shaft sub-assembly into the motor body with threaded end of shaft up. Lubricate the two o-rings with hydraulic or mineral oil before assembling.

## Assembly Instruction for Old Seal-Type Motors Old Seal Type

Weep hole is present only on motors manufactured with "old" type hydraulic seal.

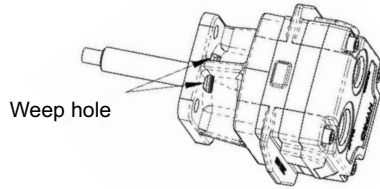

1. Install the large retaining ring onto large diameter end of shaft.
2. From the small threaded end of the shaft, install the following parts in this order: thrust bearing race, thrust bearing, 2nd thrust bearing race.

**Note:** The thrust bearing and races should not be reused if they are showing any signs of wear.

3. Install new type seal spacer provided in kit. Discard old spacer from the disassembly. (New type seal spacer looks like a thick washer, approx .130 inch thick).
4. Before installing the new seal, its lip must be expanded to fit on the shaft. With the seal lip facing out, slide the seal over the threaded end of the shaft and gently push onto the raised area of the shaft. Do not push the seal past the large retaining ring groove on the shaft.
5. Once the seal has been expanded, remove the seal from the shaft.
6. Install new type seal with seal lip facing the large end of the shaft. Slide the seal over the threaded end of the shaft and gently push onto the raised area of the shaft. Align the seal lip to enter the center diameter of the seal spacer and push until seal body touches seal spacer.

**Note:** If the seal lip is longer than the seal spacer's width, please stop the assembly and review parts being used.

7. Apply a small bead of sealant on outside of the seal body as shown (Permatex® Form-A-Gasket® No. 2 or Permatex® Gasket Sealant & Dressing No. 09974).



8. Identify new type front spacer provided in kit used only on old type motors. Discard old front spacer from the disassembly. (New type front spacer looks like a thick washer with a counter bore on one side, approx .164 inch thick).
9. Install new type front spacer by locating the counter bore side. Face this counter bore towards the seal, and slide spacer onto small end of shaft until the counter bore fits onto the seal body.
10. Finished shaft sub-assembly should look like this:



11. Do not press, but place the shaft sub-assembly into the motor body with threaded end of shaft up, taking care not to dislodge the front spacer out of its assembled place.

## Install Shaft Sub-Assembly Into Motor Body

**Important:** Make sure the surface edge of the arbor press fixture is smooth and clean. An unthreaded piece of pipe (1" x 4" high) is needed to support the outer race of the seal cartridge sub-assembly and outer race of the ball bearing during assembly. Place this pipe over the shaft threaded end for assembly of the following steps.

1. Place the body on a support fixture in the arbor press. Using an unthreaded piece of pipe (1" dia. x 4" high), press the shaft subassembly down into the body until it bottoms out. This is a light press fit and should be done slow and easy.
2. Install the new ball bearing onto the small diameter end of the shaft. Press down using the 1" x 4" pipe until the retaining ring can be installed in its groove in the bearing core of the motor body. Install the retaining ring.



Figure 15

3. Turn the motor body assembly over (threaded shaft end down) on the arbor press. Press the shaft down into its "final position" until the small retaining ring can be installed in the shaft next to the ball bearing.
4. Install small retaining ring on shaft.
5. Check shaft rotation at this point. It should rotate smoothly with only slight resistance from the seal lip pressure on the shaft. If you feel any gritty or sticking movement, return assembly to the arbor press and lightly press on the threaded end of the shaft to relieve press fit compression on the thrust bearing. **Note:** Don't over do this press. The objective is to move the small outer retaining ring installed in the previous step back to "touching only" the ball bearing inner race.

**Important:** If gritty or sticky movement persists, it's likely due to re-used parts or the body needle bearing is in need of replacement.

## Reassembly of Remaining Hydraulic Motor Parts

1. Place Motor Body in a vise with large end of shaft facing up.
2. Install the o-ring in the body.
3. Install the Roll Pin on the shaft. Place the Inner Gear of the Gerotor onto the shaft making sure Gerotor slot lines up with the key in the shaft.

**The Roll Pin can slide up behind the inner gear of the gerotor when the gear is installed. Make sure the key is visible in the slot after the gear is in place.**

4. Install the outer portion of the Gerotor, making sure the Gerotor is centered within the o-ring groove on the body.
5. Install the Gerotor Housing, making sure the pins in the Gerotor Housing line up with their respective holes in the body.
6. Lightly lubricate the area between the Inner and Outer Gerotor, the Outer Gerotor, and Gerotor Housing with hydraulic oil or mineral oil.

**Special attention should be exercised when working with retaining rings. Always wear safety goggles when working with spring or tension-loaded fasteners or devices.**

7. Install o-ring on the motor end plate.
8. Place end plate on gerotor housing, making sure holes in end plate line up with pins in the gerotor housing.
9. Install four Socket Head Cap Screws in Motor End Plate, and using a 1/4" Allen wrench, tighten Cap Screws alternately and evenly in a crisscross pattern to approximately 15 foot pounds [ 20 Nm] of torque.
10. Install the Thread Seal Gasket on the Bypass Adjusting Screw. Put the Gasket on from the slotted end and turn until four threads on the screw are

showing. Install the Washer and the Nut. Install Bypass Adjusting Screw in the motor end plate.

- A. For closed center hydraulic systems, turn the Bypass Adjusting Screw in until it bottoms out in the End Plate. Tighten nut down with 9/16" box end wrench.
  - B. For open center hydraulic systems, turn the Bypass Adjusting Screw in until it bottoms out in the End Plate; then turn back out 1½ full turns. Holding the Bypass Adjusting Screw with a screwdriver, tighten Nut. (Motor will then have to be readjusted to tractor system.)
11. Replace o-ring on both port adapters.
  12. Install Pressure Port Adapter and Tank Port Adapter back onto the motor. (For ease of installation, tighten the Pressure Port Adapter first, then the Tank Port Adapter.)
  13. Remove Hydraulic Motor from the vise. Turn shaft by hand to check for binding.
  14. Install Motor into Pump Mounting Flange. Insert four Hex Head Bolts; then alternately and evenly tighten them.

## Troubleshooting

Symptom	Probable Cause	Corrective Action
Low discharge.	The Pump is not primed.	Prime the Pump.
	Air leaks in the Suction Line.	Check for air leaks and reseal the Inlet Fittings.
	Blocked or clogged Line Strainer.	Inspect the Strainer and remove any debris from the Strainer Screen.
	Undersize or collapsed Suction Line.	The Suction Line should be the same diameter or larger than the Inlet Port of the Pump.
	Bypass Adjustment Screw in the Hydraulic Motor is not properly set.	Turn the Bypass Adjustment Screw (located on the side of the Hydraulic Motor) clockwise until the desired output is attained.
Hydraulic System overheating.	Bypass Adjustment Screw is set to bypass too much oil.	Turn the Bypass Adjustment Screw (located on the side of the Hydraulic Motor) clockwise until the desired output is attained.
	Improper Metering Orifice has been installed in the Pressure Port.	Install the proper size Metering Orifice.
	Hydraulic Hose size is too small.	Hydraulic Hose must be at least 1/2 inch diameter. For large Open Center Systems it must be at least 3/4 inch diameter.

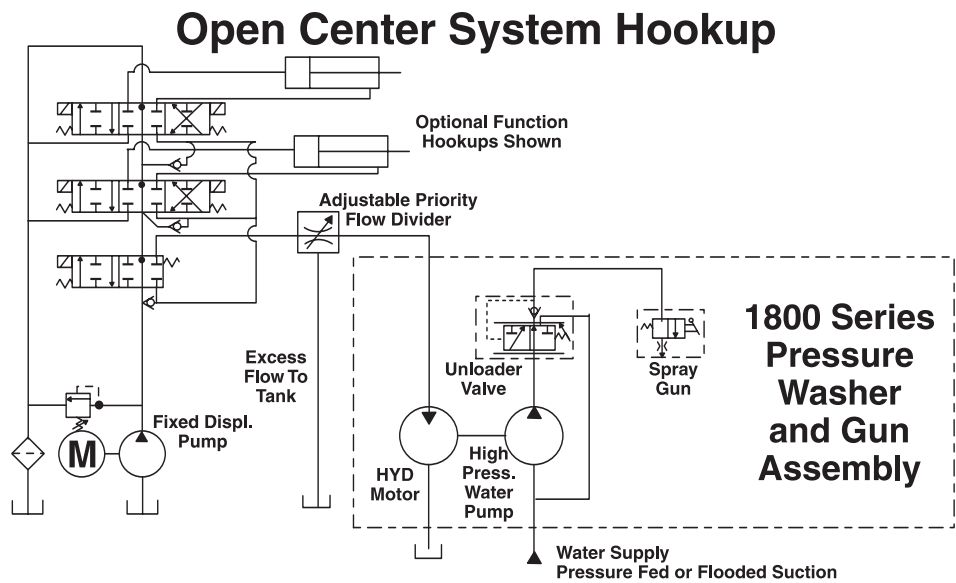
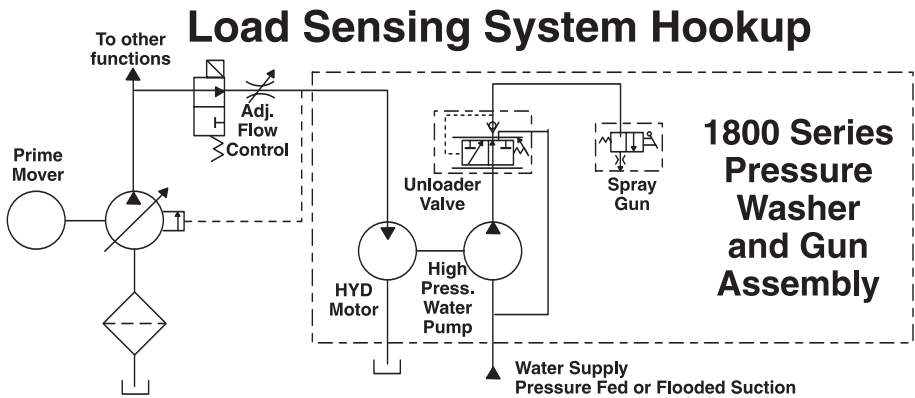
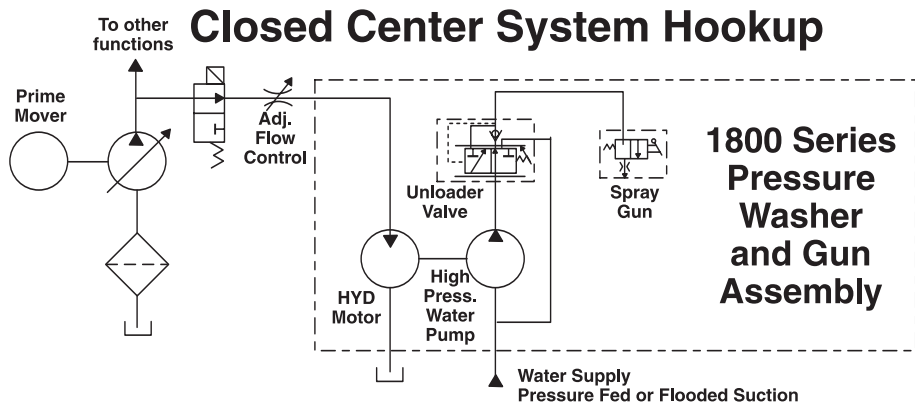

Figure 16  
Typical Hydraulic Circuit Schematics for Hydraulic-Driven Pressure Washers

# Mounting Dimensions

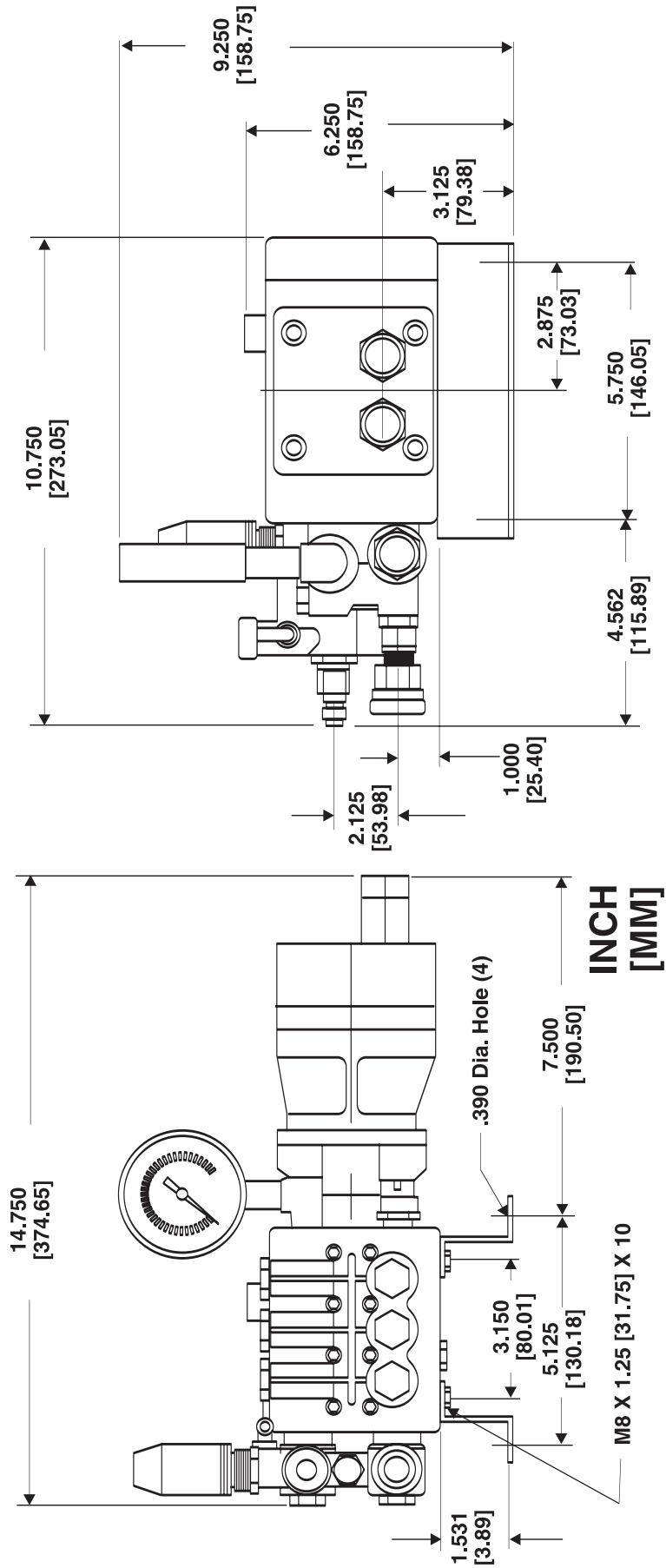
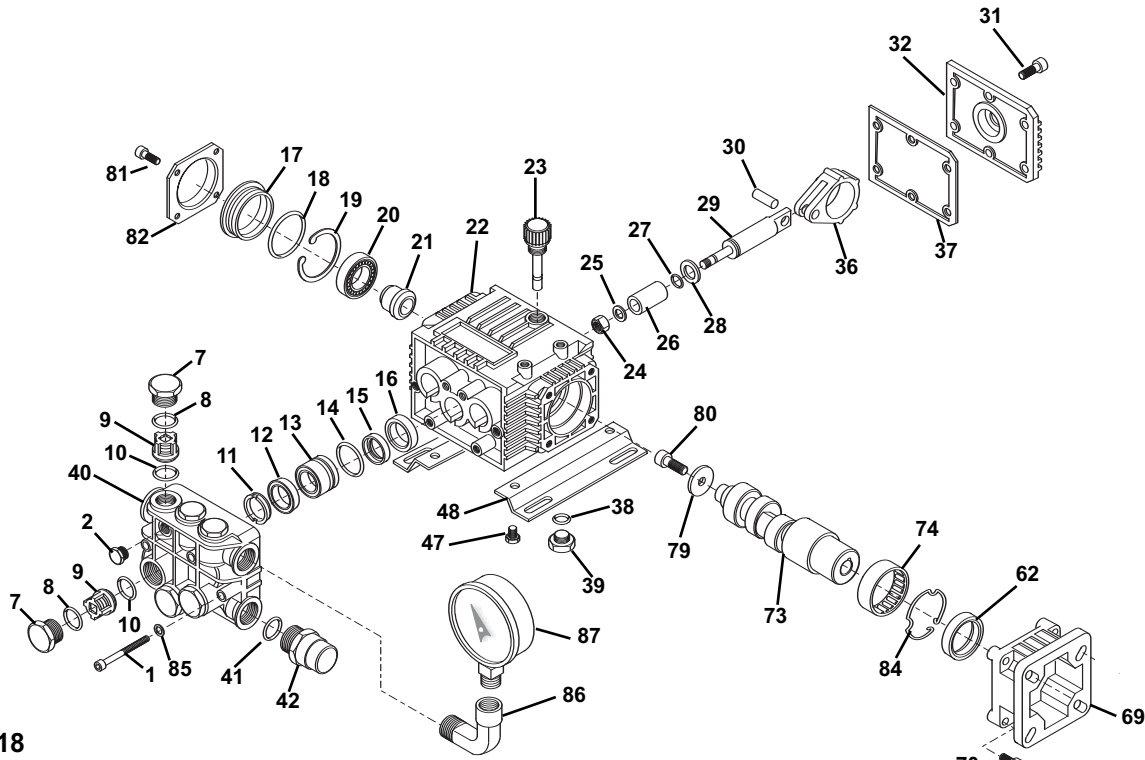

Figure 17  
Mounting Dimensions

# Models 1802C, 1803C, 1804C, 1805C, 1806C and 1807C Parts List



**Figure 18**  
**Replacement Pump Model 2257B-CX Exploded View for 1802C, 1803C, 1804C, and 1805C**  
**Replacement Pump Model 2260B-CX Exploded View for 1806C and 1807C**

Ref. No.	Part No.	Description	Qty.
1	9910-680570	Socket Head Cap Screw	6
2	9910-620301	Plug	1
7	9910-1260162	Plug	6
8 <sup>1</sup>	9910-960160	O-ring	6
9 <sup>1</sup>	3400-0133	Valve	6
10 <sup>1</sup>	9910-880830	O-ring	6
11 <sup>4</sup>	1830-0138	Support Ring	3
12 <sup>4</sup>	9910-1260220	Gasket	3
13	1830-0139	Piston Guide	3
14 <sup>4</sup>	9910-1260420	O-ring	3
15 <sup>4</sup>	9910-1260450	Gasket	3
16 <sup>3</sup>	9910-1260460	Seal	3
17	9910-1320320	Plug	1
18	9910-1320360	O-ring	1
19	9910-1260790	Retaining Ring (Internal)	1
20	9910-1320370	Bearing	1
21	9910-1320330	Bushing	1
22	9910-1320010	Pump Housing	1
23	9910-880130	Oil Plug	1
24 <sup>2</sup>	9910-1260110	Nut	3
25 <sup>2</sup>	9910-1260100	Washer	3
26 <sup>2</sup>	3500-0061	Piston	3
27 <sup>2</sup>	9910-480480	O-ring	3
28 <sup>2</sup>	9910-1260091	Spacer	3
29	9910-1260070	Guiding Piston	3
30	9910-1260080	Piston Pin	3

Ref. No.	Part No.	Description	Qty.
31	9910-1260760	Socket Head Cap Screw	6
32	9910-1269101	Complete Cover	1
36	9910-1260060	Connecting Rod (Aluminum)	3
36	9910-1320140	Connecting Rod (Bronze) 1806C/1807C	1
37 <sup>3</sup>	9910-1260040	Gasket	1
38	9910-740290	O-ring	2
39	9910-1980740	Plug	2
40	0203-2250B	Pump Head	1
41	9910-180101	O-ring	1
42	3312-0004	Thermal Relief Valve	1
47	9910-1260470	Screw	4
48	9910-1263890	Base	2
62 <sup>3</sup>	9910-480671	Seal	1
69	9910-1320050	Flange (Gas)	1
70	9910-1200430	Bolt	4
73	0551-2255	Hollow Shaft 5/8" Dia.	1
74	9910-1321190	Bearing	1
79	9910-780230	Washer	1
80	9910-780060	Socket Head Cap Screw	1
81	2220-0069	Socket Head Cap Screw	4
82	9910-1321420	Cover	1
84	9910-1321080	Snap Ring	1
85	9910-1381550	Washer	6
86	2400-0048	Elbow	1
87	2640-0005	Pressure Gauge	1

<sup>1</sup> Denotes Valve Kit item. 9910-KIT1864

<sup>2</sup> Denotes Piston Kit item. 9910-KIT2629

<sup>3</sup> Denotes Oil Seal Kit item. 9910-KIT1860

<sup>4</sup> Denotes Water Seal Kit item. 9910-KIT1874

## Models 1824C, 1825C, 1826C and 1827C Parts List

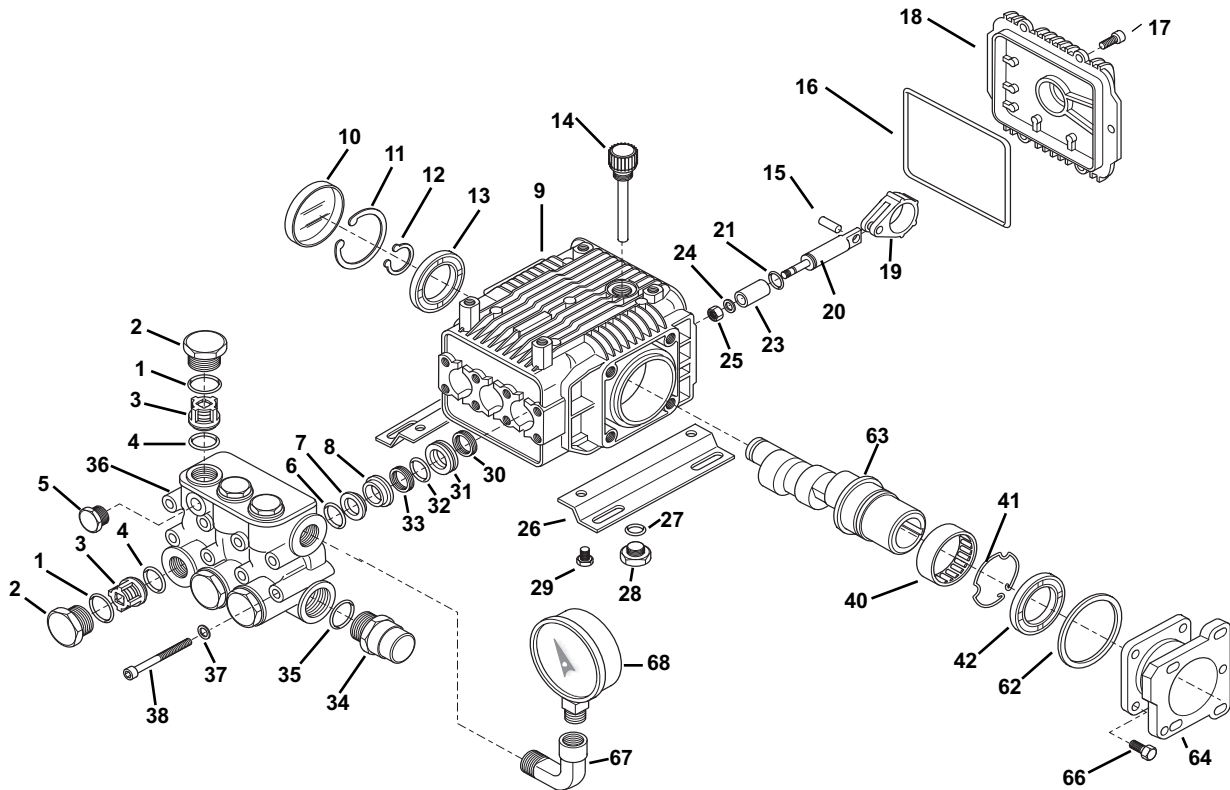

**Figure 19**  
**Replacement Pump Model 9910-XMA4G20F37 Exploded View for 1824C, 1825C, 1826C and 1827C**

Ref. No.	Part No.	Description	Qty.
1	9910-960160	O-ring	6
2	9910-1260162	Plug	6
3 <sup>1</sup>	3400-0133	Valve	6
4 <sup>1</sup>	9910-880830	O-ring	6
5	9910-620301	Plug	1
6 <sup>5</sup>	9910-1780140	Support Ring	3
7 <sup>4</sup>	9910-1260220	Gasket	3
8	9910-1780110	Piston Guide	3
9	9910-1780010	Pump Body	1
10 <sup>3</sup>	9910-1266740	Cap	1
11	9910-1260790	Retaining Ring (Internal)	1
12	9910-1780550	Retaining Ring (External)	1
13	9910-1780490	Bearing	1
14	9910-880130	Oil Cap	1
15	9910-1780050	Piston Pin	3
16 <sup>3</sup>	9910-1780510	O-ring	1
17	9910-1200430	Socket Head Cap Screw	6
18	9910-1789010	Complete Cover	1
19	9910-1780040	Connecting Rod	3
20	9910-1780060	Guiding Piston	3
21	9910-480480	O-ring	3
22	9910-1260091	Spacer Disc	3
23 <sup>2</sup>	9910-1780080	Piston	3
24	9910-1260100	Piston Washer	3

Ref. No.	Part No.	Description	Qty.
25	9910-1260110	Nut	3
26	9910-1380141	Base	2
27	9910-740290	O-ring	2
28	9910-1980740	Plug	2
29	9910-1260470	Screw	4
30 <sup>3</sup>	9910-1260460	Seal	3
31	9910-1780120	Rear Piston Guide	3
32 <sup>4</sup>	9910-770260	O-ring	3
33 <sup>4</sup>	9910-1260450	Gasket	3
34	3312-0004	Thermal Relief Valve	1
35	9910-180101	O-ring	1
36	9910-1780020	Head	1
37	9910-1381550	Washer	8
38	9910-1322730	Socket Head Cap Screw	8
40	9910-1321190	Bearing	1
41	9910-1321080	Snap Ring	1
42 <sup>3</sup>	9910-480671	Seal	1
62	9910-1780430	Bushing	1
63	9910-1780990	Hollow Shaft	1
64	9910-1780980	Gas Engine Flange	1
66	9910-180432	Bolt	4
67	2400-0048	Elbow	1
68	2640-0005	Pressure Gauge	1

<sup>1</sup> Denotes Valve Kit item. 9910-KIT1864

<sup>2</sup> Denotes Piston Kit item. 9910-KIT2746

<sup>3</sup> Denotes Oil Seal Kit item. 9910-KIT2787

<sup>4</sup> Denotes Water Seal Kit item. 9910-KIT2747

<sup>5</sup> Denotes Support Ring Kit item. 9910-KIT2745

# Unloader/Bypass Valve Model 3390-0086 (Models 1802C/1803C)

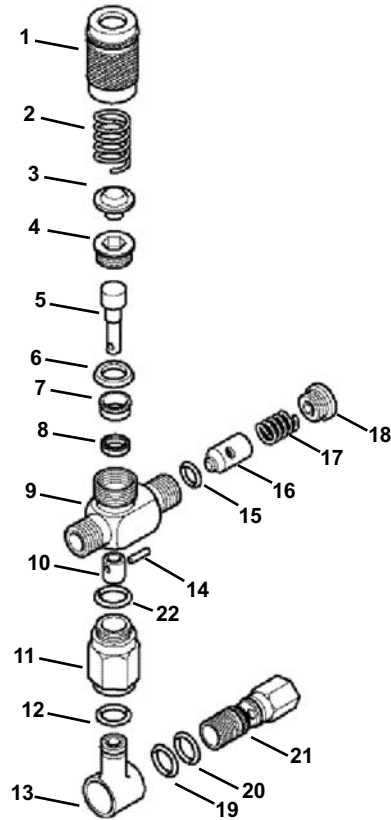

**Figure 20**  
**Injector/Unloader Seat and Seal Kit Items**

Ref. No.	Part No.	Description	Qty.
1		Pressure Adjustment Nut	
2	1900-0116	Main Spring	1
3	1900-0101	Spring Button	1
4	2404-0151	Plunger Retainer	1
5		Plunger	
6 <sup>1</sup>		Cup	
7		Sleeve	
8 <sup>1</sup>		Cup	
9		Valve Body	
10		Bypass Poppet	
11		Bypass Seal/Outlet	
12	1720-0004	O-ring	1
13	2404-0164	Bypass Adapter	1
14	1600-0041	Poppet Pin	1
15 <sup>1</sup>		O-ring	1
16		Check Valve Poppet	
17		Check Valve Spring	
18	1830-0115	Poppet Retainer	1
19	1720-0004	O-ring	1
20	1720-0064	O-ring	1
21	2404-0164	Bypass Adapter	1
22 <sup>1</sup>		O-ring	1

<sup>1</sup> Denotes Repair Kit item. Repair Kit No. 3430-0223

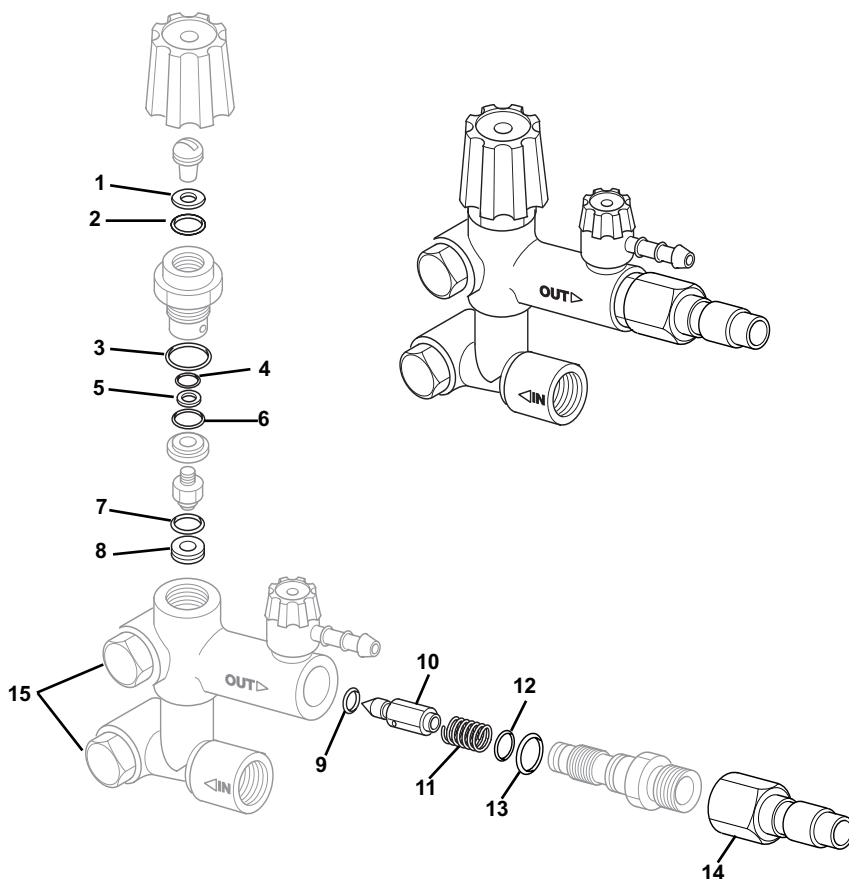
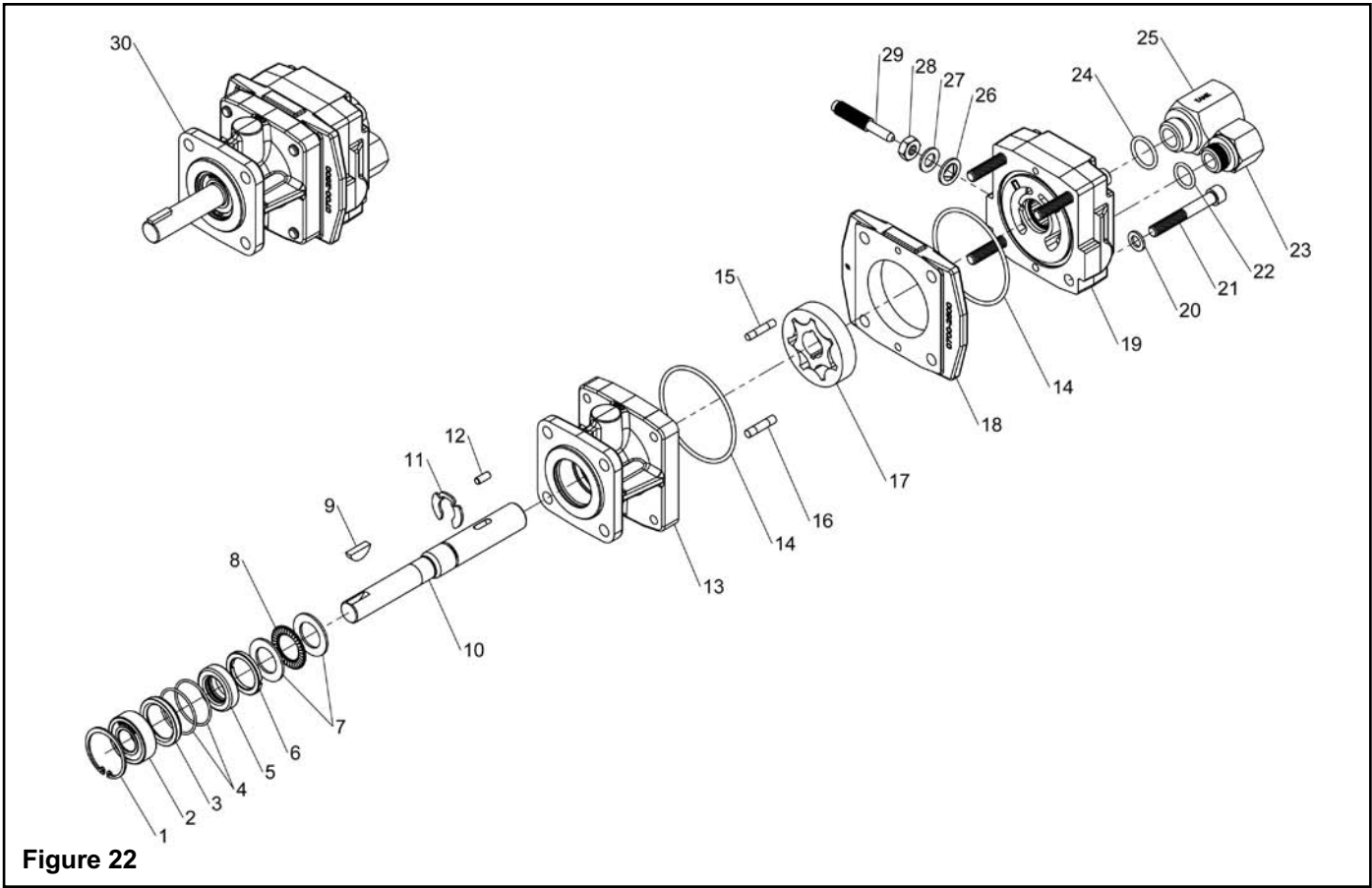

**Figure 21**  
**Unloader Assembly Items**

Ref. No.	Part No.	Description	Qty.
1 <sup>1</sup>	Repair Kit Item	Washer	1
2 <sup>1</sup>	Repair Kit Item	O-ring	1
3 <sup>1</sup>	1720-0186	O-ring	1
4 <sup>1</sup>	Repair Kit Item	O-ring	1
5 <sup>1</sup>	Repair Kit Item	Washer	1
6 <sup>1</sup>	1720-0196	O-ring	1
7 <sup>1</sup>	1720-0163	O-ring	1
8 <sup>1</sup>	3210-0080	Valve Seat	1
9 <sup>1</sup>	1720-0190	O-ring	1
10 <sup>1</sup>	3320-0035	Piston	1
11 <sup>1</sup>	1900-0161	Spring	1
12 <sup>1</sup>	Repair Kit Item	O-ring	1
13 <sup>1</sup>	Repair Kit Item	O-ring	1
14	9900-38FPB	Quick Disconnect (Male End)	1
15	3430-0483	Bolt Kit Assembly (NPT)	1
15	3430-0487	Bolt Kit Assembly (BSP)	1

<sup>1</sup> Denotes Parts Kit items. Parts Kit No. 3430-0484

## Model No. 2500-0087C and 2500-0088C Hydraulic Motor Parts List



**Figure 22**

Ref. No.	Part No.	Description	Qty.
1	1820-0013	Retaining Ring (Int.)	1
2 <sup>1</sup>	2000-0010	Ball Bearing	1
3	1410-0131	Front Cartridge (2010 & newer models)	1
3	1410-0073	Front Spacer (Models before 2010)	1
4 <sup>1</sup>	1720-0268	O-ring(2010 & newer models)	2
4		(Not used in Models before 2010)	
5 <sup>1</sup>	2104-0010	Mechanical Seal	1
6	1410-0130	Spacer(2010 & newer models)	1
6	1410-0074	Seal Spacer (Models before 2010)	1
7	2029-0010	Thrust BearingRace	2
8	2029-0009	Thrust Bearing	1
9	1610-0012	Key	1
10	0530-2500	Shaft (Models 1802C/1803C, 1804C/1805C)	1
10	0532-2500	Shaft (Models 1806C/1807C, 1824C/1825C, 1826C/1827C)	1
11	1810-0026	Snap Ring	1
12	1610-0031	Key (Models 1802C/1803C, 1804C/1805C)	1
12	1610-0055	Key (Models 1806C/1807C, 1824C/1825C, 1826C/1827C)	1
13	0150-2500C	Motor Body (Includes Main Bearing)	1
14 <sup>1</sup>	1720-0110	O-ring	2
15	1600-0037	Dowel Pin (Models 1802C/1803C, 1804C/1805C)	1
15	1600-0068	Dowel Pin (Models 1806C/1807C, 1824C/1825C, 1826C/1827C)	1

Ref. No.	Part No.	Description	Qty.
16	1600-0044	Dowel Pin(Models 1802C/1803C, 1804C/1805C)	1
16	1600-0052	Dowel Pin (Models 1806C/1807C, 1824C/1825C, 1826C/1827C)	1
17	3900-0022	Gerotor Assy (Models 1802C/1803C, 1804C/1805C)	1
17	3900-0024	Gerotor Assy (Models 1806C/1807C, 1824C/1825C, 1826C/1827C)	1
18	0700-2500C	Gerotor Housing (Models 1802C/1803C, 1804C/1805C)	1
18	0702-2500C1	Gerotor Housing (Models 1806C/1807C, 1824C/1825C, 1826C/1827C)	1
19	0254-2500C2	Motor Endplate (Includes Main Bearing)	1
20	2270-0039	Washer	4
21	2220-0021	CAP SCREW (Models 1802C/1803C, 1804C/1805C)	4
21	2220-0032	CAP SCREW (Models 1806C/1807C, 1824C/1825C, 1826C/1827C)	4
22 <sup>1</sup>	1720-0108	O-ring	1
23	3360-0021A	Pressure Port Adapter	1
24 <sup>1</sup>	1720-0262	O-ring	1
25	3320-0051A	Tank Port Adapter	1
26 <sup>1</sup>	1700-0047	Gasket	1
27 <sup>1</sup>	2270-0027	Washer	1
28	2250-0038	Jam Nut	1
29	3220-0029	Bypass Adjusting Screw	1
30	2500-0088C	Motor Assy (Models 1802C/1803C, 1804C/1805C)	1
30	2500-0087C	Motor Assy(Models 1806C/1807C, 1824C/1825C, 1826C/1827C)	1

<sup>1</sup> Denotes Parts Kit item. Parts Kit No. 3430-0748

## Gun, Lance, Nozzle and Hose Assembly Parts List

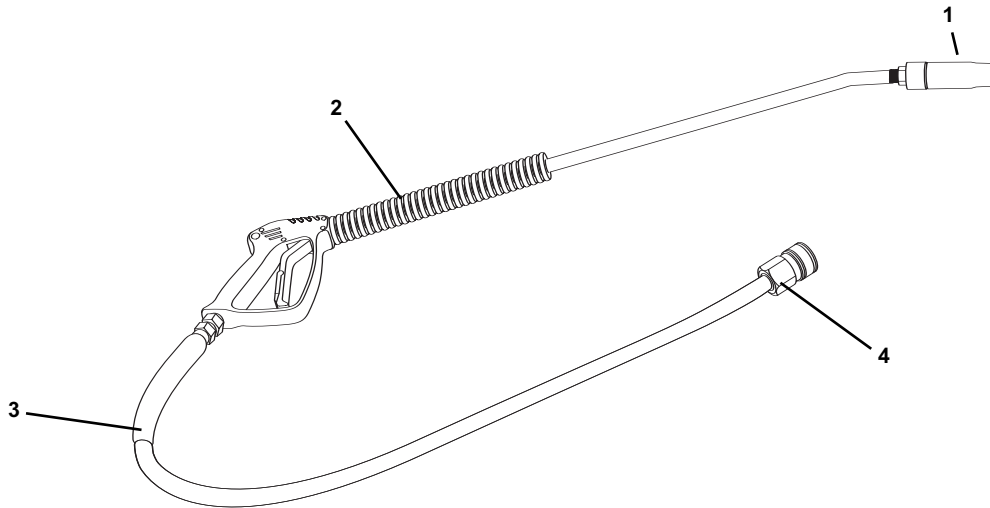
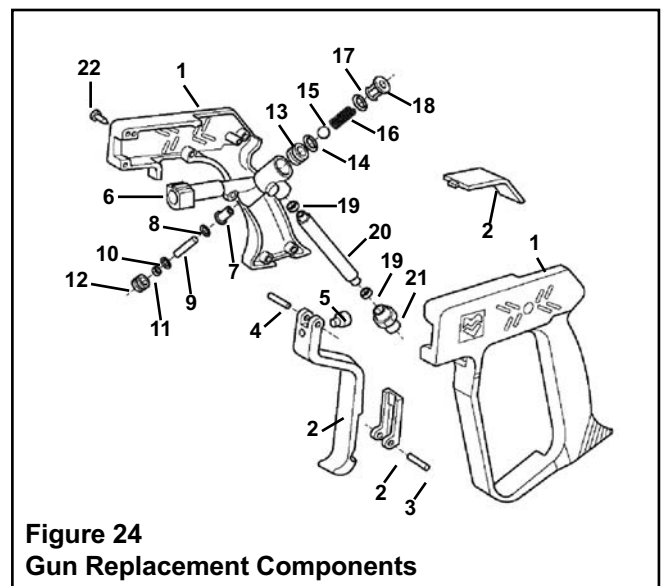

**Figure 23**  
Gun, Lance, and Hose Replacement Components

Model No.	Full Assembly No.	Ref. No. 1 Nozzle No.	Ref. No. 2 Gun & Lance No.	Ref. No. 3 Hose No.	Ref. No. 4 Q.C. No.
1802	8000-0028	3324-1001.5	3381-0031	2900-0042	9900-38FS
1804	8000-0031	3324-2001.4	3381-0031	2900-0042	9900-38FS
1806	8000-0030	3324-2001.25	3381-0031	2900-0042	9900-38FS
1824	8000-0048	3324-2001.5	3381-0031	2900-0042	9900-38FS
1826	8000-0049	3324-2001.35	3381-0031	2900-0042	9900-38FS

## Gun Parts List

Ref. No.	Part No.	Description	Qty.
1	2800-0023	Case (Right and Left)	1
2	2825-0023	Trigger	1
3	1610-0049	Pin	1
4		Trigger Pin	1
5		Trigger Wear Pin	1
6		Body (3381-0018)	1
7	Repair Kit Item	Plunger Sleeve	1
8	Repair Kit Item	O-ring (Viton)	1
9	Repair Kit Item	Plunger	1
10	Repair Kit Item	O-ring (Viton)	1
11	Repair Kit Item	Seal	1
12	Repair Kit Item	Retainer	1
13	3210-0081	Seat (3381-0018)	1
13	3210-0083	Seat (3381-0018 Std.)	1
14	1720-0163	O-ring	1
15	Repair Kit Item	Ball	1
16	Repair Kit Item	Spring	1
17	Repair Kit Item	O-ring	1
18	Repair Kit Item	Retainer	1
19	2270-0068	Seal (Washer)	2
20	2404-0223	Tube (Inlet)	1
21	2404-0224	Tube (Adapter)	1
22	2200-0038	Screw	7



**Figure 24**  
Gun Replacement Components

Repair Kit No. 3430-0398





## Limited Warranty on Hypro/SHURflo Agricultural Pumps & Accessories

Hypro/SHURflo (hereafter, "Hypro") agricultural products are warranted to be free of defects in material and workmanship under normal use for the time periods listed below, with proof of purchase.

- Pumps: one (1) year from the date of manufacture, or one (1) year of use. This limited warranty will not exceed two (2) years, in any event.
- Accessories: ninety (90) days of use.

This limited warranty will not apply to products that were improperly installed, misapplied, damaged, altered, or incompatible with fluids or components not manufactured by Hypro. All warranty considerations are governed by Hypro's written return policy.

Hypro's obligation under this limited warranty policy is limited to the repair or replacement of the product. All returns will be tested per Hypro's factory criteria. Products found not defective (under the terms of this limited warranty) are subject to charges paid by the returnee for the testing and packaging of "tested good" non-warranty returns.

No credit or labor allowances will be given for products returned as defective. Warranty replacement will be shipped on a freight allowed basis. Hypro reserves the right to choose the method of transportation.

This limited warranty is in lieu of all other warranties, expressed or implied, and no other person is authorized to give any other warranty or assume obligation or liability on Hypro's behalf. Hypro shall not be liable for any labor, damage or other expense, nor shall Hypro be liable for any indirect, incidental or consequential damages of any kind incurred by the reason of the use or sale of any defective product. This limited warranty covers agricultural products distributed within the United States of America. Other world market areas should consult with the actual distributor for any deviation from this document.

### Return Procedures

All products must be flushed of any chemical (ref. OSHA section 1910.1200 (d) (e) (f) (g) (h)) and hazardous chemicals must be labeled/tagged before being shipped\* to Hypro for service or warranty consideration. Hypro reserves the right to request a Material Safety Data Sheet from the returnee for any pump/product it deems necessary. Hypro reserves the right to "disposition as scrap" products returned which contain unknown fluids. Hypro reserves the right to charge the returnee for any and all costs incurred for chemical testing, and proper disposal of components containing unknown fluids. Hypro requests this in order to protect the environment and personnel from the hazards of handling unknown fluids.

Be prepared to give Hypro full details of the problem, including the model number, date of purchase, and from whom you purchased your product. Hypro may request additional information, and may require a sketch to illustrate the problem.

**Contact Hypro Service Department at 800-468-3428 to receive a Return Merchandise Authorization number (RMA#).** Returns are to be shipped with the RMA number clearly marked on the outside of the package. Hypro shall not be liable for freight damage incurred during shipping. Please package all returns carefully. All products returned for warranty work should be sent **shipping charges prepaid** to:

HYPRO  
Attention: Service Department  
375 Fifth Avenue NW  
New Brighton, MN 55112

For technical or application assistance, call the **Hypro Technical/Application number: 800-445-8360**. To obtain service or warranty assistance, call the **Hypro Service and Warranty number: 800-468-3428**; or send a fax to the **Hypro Service and Warranty FAX: 651-766-6618**.

\*Carriers, including U.S.P.S., airlines, UPS, ground freight, etc., require specific identification of any hazardous material being shipped. Failure to do so may result in a substantial fine and/or prison term. Check with your shipping company for specific instructions.

