

Installation Instructions and Parts List

Adapter Kit No. 8000-0017—Mounts PowerLine 2400 and 2430 pumps to a 213TC/215TC C-flange motor.

Adapter Kit No. 8000-0018—Mounts PowerLine 2400 and 2430 pumps to a 182TC/184TC C-flange motor.

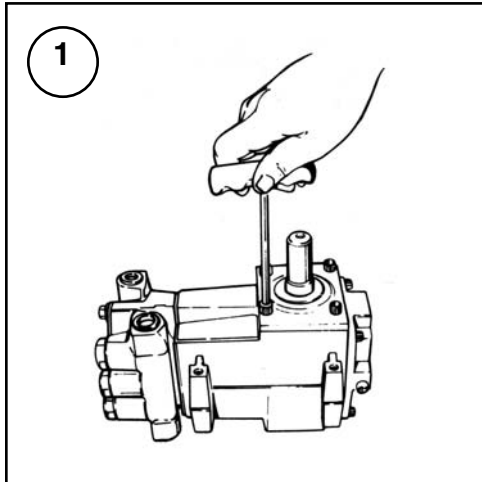

Turn pump on its side, shaft up. Remove four bolts on the bearing cover. Bolts are removed with a 1/4" Allen wrench.

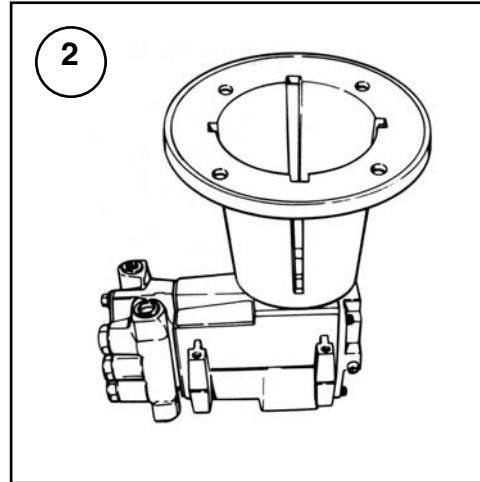

Position the C-flange over the bearing cover of the pump. Line up bolt holes by rotating the flange.

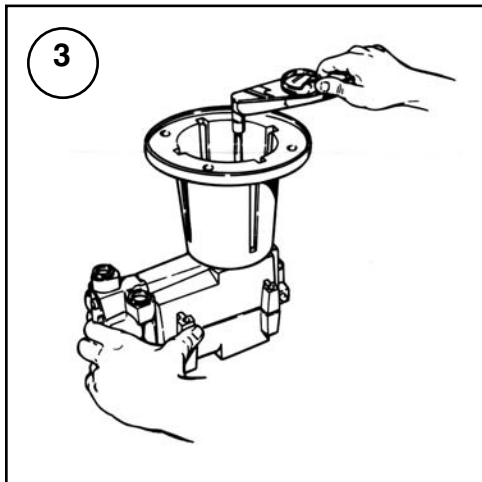

Secure the C-flange to the pump using 1-1/4" long bolts. Apply Loctite to each bolt and torque to 120-150 in.lbs.

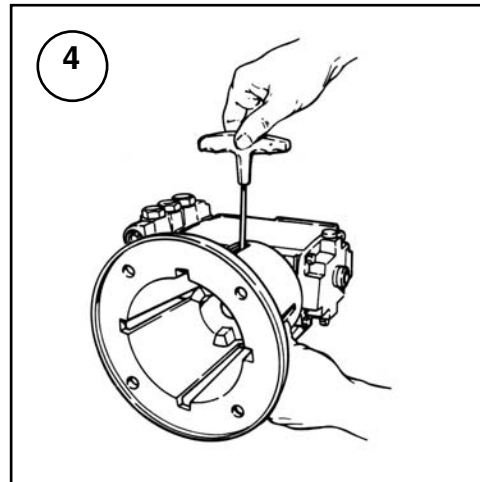

Install the key into the pump shaft and install the coupling half flush with the end of the shaft. Tighten the set screw on the coupling half.

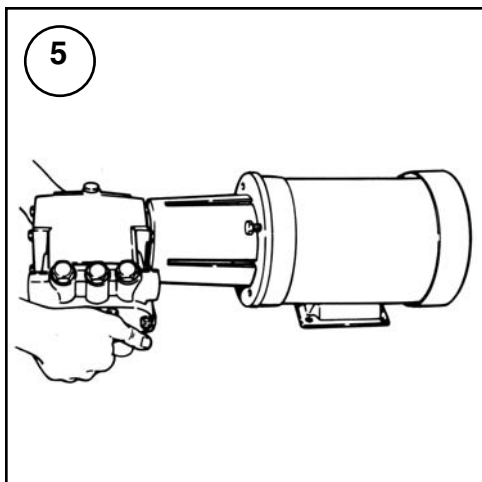

Install the key on the motor shaft and install the coupling half. Slide the center disc into the coupling half. Install the pump flange assembly onto the motor and secure with bolts.

Parts List 8000-0017 for NEMA 213TC and 215TC Motors

Ref. No.	Part No.	Description	Qty. Req'd.
1	0706-8800A	Flange	1
2	2210-0083	Bolts	4
3	2220-0055	Bolts	4
4	2160-0017	Loctite	2

Parts List 8000-0018 for NEMA 182TC and 184TC Motors

Ref. No.	Part No.	Description	Qty. Req'd.
1	0705-8800A	Flange	1
2	2210-0083	Bolts	4
3	2220-0055	Bolts	4
4	2160-0017	Loctite	2

Note: Order the coupling half separately from the flange kit.

