



Cleanload™ Chemical Educator

Form L-1477
(3/12, Rev. B)

Operation and Parts Manual

Description



3375P-05T4 hopper ball valve, inlet ball valve (shown)

3375P-05T4-01 hopper ball valve, no inlet ball valve

Chemical Educator with 4.5 gallon hopper for smaller areas. Features a 316 stainless steel venturi. Side-wall mounted tank rinse can be operated while the 12" hinged lid is open for complete rinsing. Can be used for mixing liquid or dry chemicals.

Ports:
Inlet port 1¼" FNPT
Outlet port 1½" MNPT



3375P-05T5 hopper ball valve, inlet ball valve (shown)

3375P-05T5-01 hopper ball valve, no inlet ball valve

Chemical Educator with 5.5 gallon hopper and 316 stainless steel venturi. Ideal for mixing liquid and dry chemicals. Tank rinse nozzle mounted in the 12" hinged lid provides aggressive hopper clean out. Also includes an in-hopper bottle rinse system for rinsing chemical containers onsite. Equipped to fit optional suction lance (part # 3430-0594).



3375P-05T7 hopper ball valve, inlet ball valve (shown)

Chemical Educator with 7 gallon hopper and 316 stainless steel venturi. Ideal for mixing liquid and dry chemicals. Tank rinse nozzle mounted in the 16" hinged lid provides aggressive hopper clean out. Also includes an in-hopper bottle rinse system for rinsing chemical containers onsite and accommodates most 20L containers.



Suction Lance Kit - PN 3430-0594
(used with 3375P-05T5 & 3375P-05T5-01)

Compatible with 5.5 gallon models only, the suction lance kit includes: 6' suction hose, 3' lance and o-ring sealed coupler. Allows for loading of liquid chemical and powders without lifting or pouring containers.



Base Kit - PN 3430-0596

Base kit for mounting Cleanload educators rigid to floor in stationary and tender-truck applications. Four 3/8" holes provided in base.



Hopper Outlet Screen - PN 3350-0148

Removable screen to prevent large debris from passing through the hopper into the educator venturi.

Low Flow Kit - PN 1530-0040

Orifice kit adapts Cleanload educator venturi for use in systems with pumps having output as low as 14 GPM @ 40 PSI (55L/min @ 3 bar), such as some turf sprayers equipped with diaphragm pumps.

Safety Warnings and Precautions

Always wear protective clothing when handling chemicals. Adhere to cautions on container labels. Check hoses and fittings on a regular basis for leaks or damaged parts. Replace hose if crack appears in hose. Read operating instructions before operating Cleanload Eductor. Failure to follow proper procedures may cause injury or contamination by chemical being educted.

Installation Instructions

The Cleanload chemical loading station is a versatile tool that can be used in a variety of applications. Because of the wide range of equipment Cleanload stations may be used with, it is not possible to list every installation detail. Consult the manufacturer's documentation for the equipment on which you are mounting the station to identify suitable plumbing connections and mounting locations.

- Securely mount the Cleanload station in a place that is out of the way of moving equipment, protected from crops and terrain, and allows for safe routing of plumbing. Bolt in place using 3/8" or 10mm hardware. For mobile installations, the station should be attached to substantial framework capable of supporting it over rough terrain. For-floor mounted installations, use a base kit, part number 3435-0596.
- Connect inlet and outlet hoses using appropriate fittings. Hoses should be rated for use with the chemicals being used. In agricultural applications, 200 psi rated braided EPDM hose is suggested.
- The arrow on the eductor fitting indicates the direction of flow. The inlet of the eductor fitting is 1-1/4" MNPT, and some models are fitted with a 1-1/4" FNPT inlet ball valve. The outlet is 1-1/2" MNPT.
- For on-board sprayer installations, the hose from the outlet should be routed to the top of the spray tank to prevent back-flow. Include anti-siphoning provisions, such as a one-way check valve, if a stand pipe is used inside the tank to discharge chemical under the tank, or if top-routing is not possible.
- Elbow fittings, reducers, check valves, and sharp turns in the plumbing create back-pressure on the eductor and reduce performance. Their use should be minimized. Instead of sharp turns or elbow fittings, make sweeping bends with reinforced hose. If sharp turns cannot be avoided, the plumbing should be oversized to reduce flow restriction. Do not reduce the size of the outlet hose or fittings.
- To gain the full benefit of the rinse systems built into the Cleanload station, provision should be made so that the final rinse is made using clean water.
 - o For on-board sprayer installations, a clean water rinse tank should be connected to the pump inlet with a 3-way valve to allow for a final clean water flush. This is a common standard feature on large modern sprayers.
 - o For transfer and tender truck installations, the final rinse can simply be made when clean water is being transferred into the spray tank.

Typical On-Board Sprayer Installation

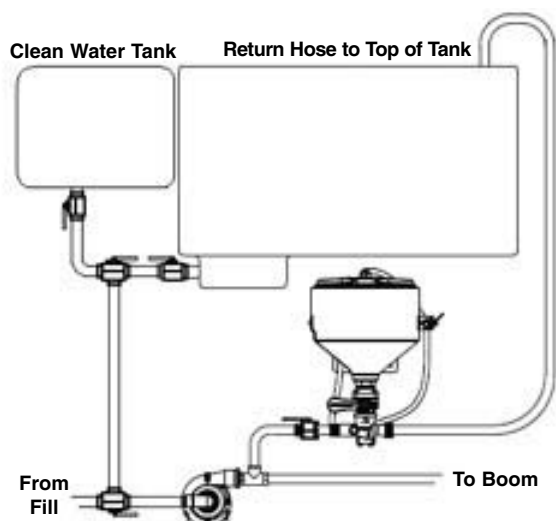

Typical Transfer / Tender Installation

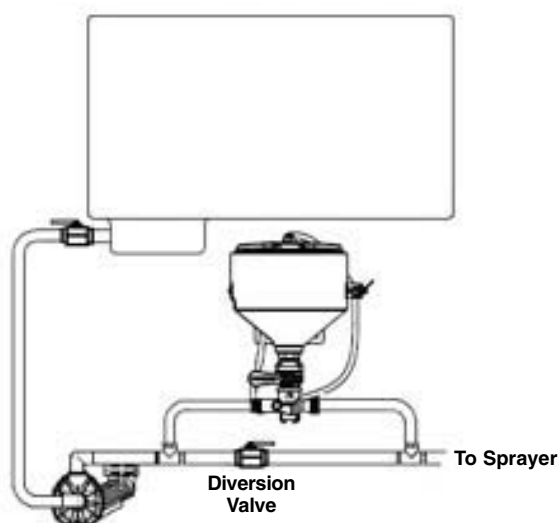

Operating Instructions

WARNINGS AND PRECAUTIONS

- ⚠ READ operating instructions prior to using the Cleanload loading station.
 - ⚠ ALWAYS read and follow the chemical label instructions exactly. Understand safe practices for chemical handling, mixing, loading, and cleanup; and first aid.
 - ⚠ ALWAYS wear the required Personal Protective Equipment.
 - ⚠ DO NOT operate equipment with missing, damaged, or leaking parts. Inspect for damaged parts before each use.
 - ⚠ DO NOT operate valves out of sequence. DO NOT open the lid while the ProClean Hopper Rinse System is in operation. DO NOT operate the ProClean Hopper Rinse System while the lid is open. Failure to follow proper procedures may cause injury or contamination.
 - ⚠ DO NOT use the ProClean Container Rinse System to rinse containers that are too large to fit freely through the hopper lid opening.
 - ⚠ ALWAYS open the lid slowly to verify it is safe to fully open the lid. Keep your head and face away from the lid opening.
 - ⚠ ALWAYS pour chemicals carefully to prevent splashing and spills.
 - ⚠ IMMEDIATELY close the lid and SHUT DOWN the system if leaks, errant spray, operation error, or malfunction is detected.
-

Before Operation

1. Ensure all Cleanload valves are closed prior to starting.
2. Unlock the lid by turning it counterclockwise, and open it. Inspect the hopper for cleanliness, remove foreign objects, and ensure the optional hopper outlet screen is properly seated.
3. Close the lid and lock it by turning it clockwise. Gently lift on the lid to ensure it is locked closed. If the lid will not close, will not lock, or is damaged, STOP and repair it before further use.

Start Up

4. Divert pump flow to the Cleanload inlet line.
5. Open the INLET VALVE on the eductor fitting.
6. Open the HOPPER OUTLET VALVE.
7. Unlock the lid by turning it counterclockwise. Open the lid slowly, taking care to check that no errant spray is detected before fully opening the lid.

Pouring Chemical into the Hopper

8. If the Cleanload is equipped with a Sidewall Rinse System, open the SIDEWALL RINSE VALVE.
9. Measure the required amount of chemical using an accurate measuring vessel, scale, or flow meter. The hopper should not be used as a measurement vessel.
10. Carefully pour the chemical into the hopper taking care to not splash or spill.

NOTE: To accelerate dissolving and educting dry chemicals, at this point, the operator may wish to flush the hopper using the ProClean Hopper Rinse System. Follow the instructions in steps 22 through 26.

11. If the Cleanload is equipped with a ProClean Container Rinse System, it can be used to rinse empty liquid containers using steps 11 through 13.
12. Place the container to be rinsed upside down over the nozzle in the bottom of the hopper. Holding the container securely with two hands, press down to activate the CONTAINER RINSE VALVE for 30 seconds or longer until container is visibly clean.

(Continued)

Operating Instructions - cont'd.

13. When the container is visibly clean, stop pressing down. The CONTAINER RINSE VALVE will close and the spray will stop. Let the container drain until empty, then set it aside for proper recycling or disposal.
14. If the Cleanload is equipped with a Sidewall Rinse System, allow it to operate for 30 additional seconds or longer to flush residues, and then close the SIDEWALL RINSE VALVE.

Using the optional Cleanload Suction Lance

15. Ensure the hopper has been rinsed of chemical residue. If equipped with an optional hopper outlet screen, remove it by pulling it straight up from the outlet. Set it aside for later.
16. Insert the lance body into the eductor until the o-ring seals on the hopper drain.
17. Use the end of the lance to pierce the bag or foil seal, and suction up the chemical.
18. When the desired amount of chemical has been suctioned up, raise the end of the lance slightly out of the chemical but keep it in the container to let the lance drain out.
19. Place the end of the lance into a container of clean rinse water. Suction for 30 seconds or more to clean the lance, and then raise the end slightly out of the water to let the lance drain out.
20. Point the end of the lance up and raise it above the hopper to drain any remaining water into the eductor. Ensure the hose is fully emptied into the eductor, then remove the lance from the eductor, and pour the container of rinse water into the hopper.
21. Reinstall the optional hopper outlet screen.

Using the optional ProClean Hopper Rinse System

22. Close the lid and lock it by turning it clockwise. Gently lift on the lid to ensure it is locked closed.
23. Release the safety lock on the HOPPER RINSE VALVE and open that valve. Operate the ProClean Hopper Rinse System for 30 seconds.
24. Close the HOPPER RINSE VALVE and return the safety lock to the locked position.
25. Unlock the lid by turning it counterclockwise. Open the lid slowly, taking care to check that no errant spray is detected before fully opening the lid.
26. Inspect the hopper for visible chemical residue. Repeat steps 22 through 26 as necessary.

Shutdown

27. Ensure chemical residue has been flushed from the system, the rinse system valves are closed, and the optional hopper outlet screen is in place.

NOTE: The final container rinse, sidewall rinse and hopper rinse outlined in steps 8-14 and 22-26 should be made using clean water. For sprayers equipped with a clean water rinse tank, follow the sprayer manufacturer's instructions for pumping from the clean water tank during the final rinse. For transfer and tender truck installations, the final rinse should be made while transferring clean water.

28. Close the lid and lock it by turning it clockwise. Gently lift on the lid to ensure it is locked closed.
29. Close the HOPPER OUTLET VALVE.
30. Close the INLET VALVE.
31. If pump flow has been diverted to the Cleanload, divert it back for normal spraying or transfer.

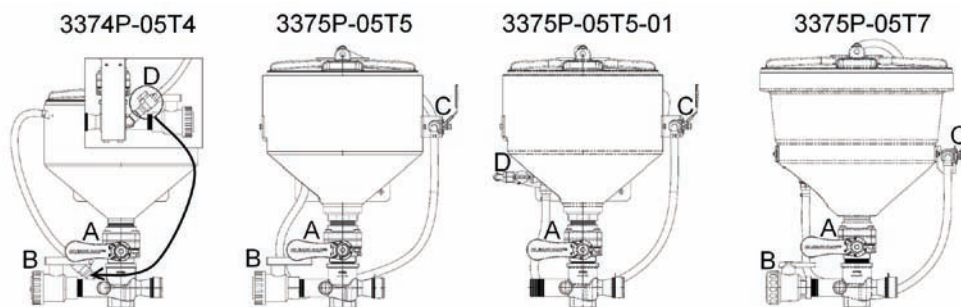

Troubleshooting

Symptom	Corrective Action
Slow Education Rate	<ol style="list-style-type: none"> 1. Minimize flow restrictions on the downstream side of the eductor. Replace 90-degree fittings with sweeping bends using reinforced hose, especially near the eductor outlet. Use 1-1/4", 1-1/2" (32mm, 38mm) or larger hose and fittings all the way back to and into the tank. If sharp bends cannot be avoided, use oversized hose and fittings to minimize flow restriction. 2. The eductor nozzle is plugged. Looking down into the hopper outlet, the liquid jet should be centered and straight. If it is off-center or if it is dispersed, flush the system with clean water and remove the fittings from both sides of the eductor. Using a soft tool (wood or plastic) and using care to not deform the orifice, clear the blockage by pushing it back out toward the inlet side of the fitting. A blocked eductor nozzle indicates that a filtration problem elsewhere in the system must be corrected. 3. Flow and pressure may be too low. Verify the rated pump performance is adequate for your Cleanload model's flow rate table. The pressure at the eductor should be 30 PSI (2bar) or greater. The 1/2" FNPT port on side of the eductor fitting can be used as a gauge port. If pressure is low, it indicates trouble elsewhere in the system. Recheck pressure after each attempted improvement: increase pump output, clean filters, divert more flow to the Cleanload, reduce pump bypass on systems using roller or diaphragm pumps, reduce tank agitation, close the Sidewall Rinse Valve during education. Kit No. 3410-0040 can improve performance in systems with pumps supplying less than 35 GPM (130 L/min.).
Poor Lance Suction	<ol style="list-style-type: none"> 1. Granules may be too coarse. Coarse product may need to be poured into the hopper. 2. Flow and pressure may be too low. The lance functions best at the highest operating pressures. See action for "Slow Education Rate."
Plugged Container Rinse Nozzle	Remove the screw from the top of the nozzle, remove the rotary head, and rinse it in a container of clean water. Flush the rinse system by following operating instructions steps 11 to 13 using clean water. Reassemble the nozzle. A blocked rinse nozzle indicates that a filtration problem elsewhere in the system must be corrected.
Plugged Hopper Rinse Nozzle	Remove the screw from the top of the nozzle, remove the rotary head, and rinse it in a container of clean water. Flush the rinse system by following operating instructions steps 22 to 27 using clean water. Reassemble the nozzle. A blocked rinse nozzle indicates that a filtration problem elsewhere in the system must be corrected.
Leaks	<ol style="list-style-type: none"> 1. Check for loose or cracked fittings. Tighten or replace. 2. Check for thread leaks. Disassemble and reseal fittings TPF E thread sealant or TPF E tape. Secure plumbing and hose so its weight does not cause fittings to turn or vibrate loose. 3. Prevent freeze damage by winterizing the sprayer.

Cleanload Eductor Performance

Standard Installations

US Units

Inlet Pressure PSI	Inlet Flow GPM	Tank Eduction seconds/gal	Lance Eduction* seconds/gal	Max. Outlet Head feet
20	30	3.6	6.7	11.3
30	35	2.3	4.3	16.2
40	40	1.8	3.3	20.8
50	45	1.5	2.9	25.4
60	50	1.3	2.6	30.7
70	54	1.1	2.4	35.8
80	57	1.0	2.3	41.1
90	61	1.0	2.2	46.2
100	64	0.9	2.2	51.5

Metric Units

Inlet Pressure bar	Inlet Flow L/min	Tank Eduction seconds/liter	Lance Eduction* seconds/liter	Max. Outlet Head meters
1.4	109	0.95	1.75	3.4
2	131	0.63	1.18	4.7
3	160	0.45	0.82	6.9
4	185	0.35	0.70	9.1
5	206	0.28	0.63	11.4
6	226	0.26	0.58	13.6
7	244	0.23	0.58	15.8

*Lance is compatible with 5.5 gallon models only

Optional Kit 3410-0040 Installed

US Units

Inlet Pressure PSI	Inlet Flow GPM	Tank Eduction seconds/gal
40	14	5.3
50	16	3.6
60	18	2.8
70	20	2.1
80	22	1.7
90	23	1.4
100	24	1.2

Metric Units

Inlet Pressure bar	Inlet Flow L/min	Tank Eduction seconds/liter
3	55	1.22
4	64	0.78
5	71	0.52
6	78	0.38
7	84	0.32

Dimensions

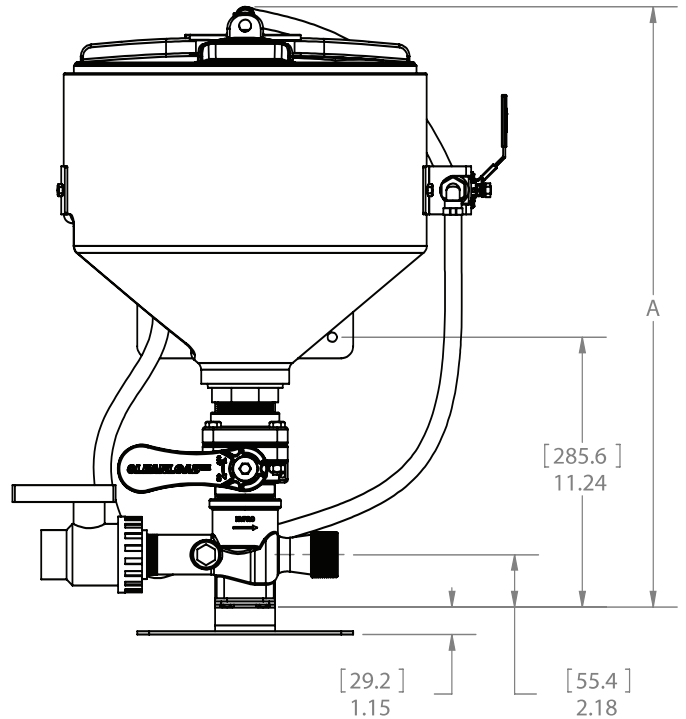
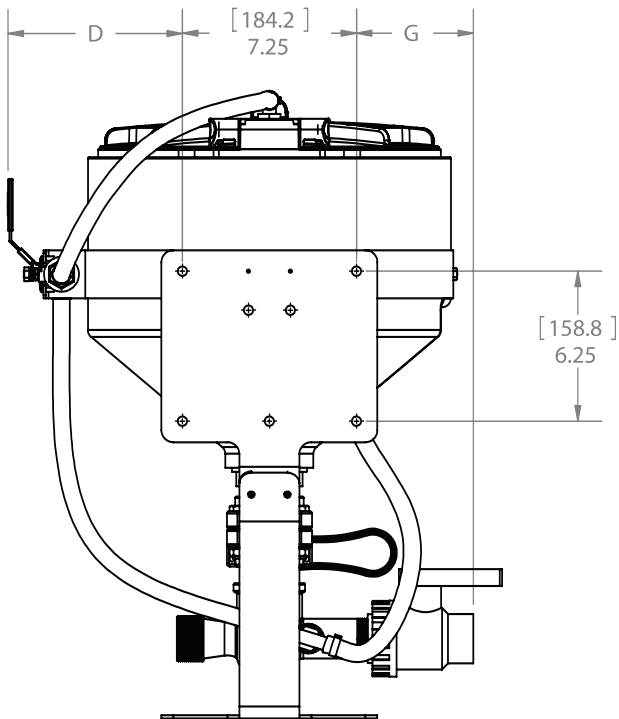
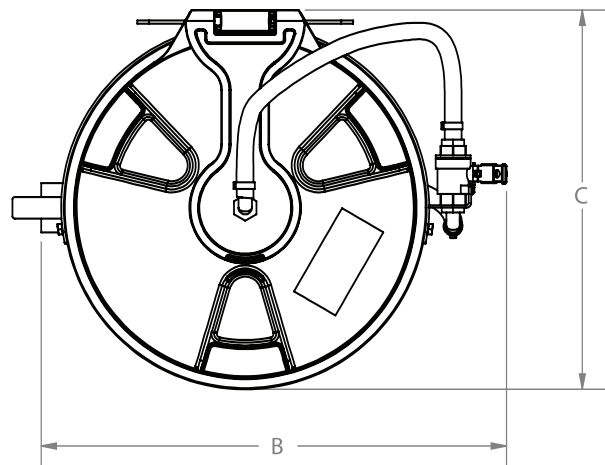
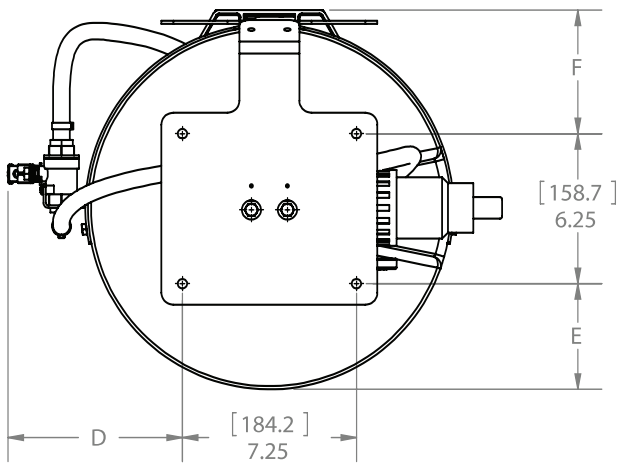

	Model			
	3375P-05T4	3375P-05T5	3375P-05T5-01	3375P-05T7
A	21.0	25.0	25.0	25.1
B	16.0	19.5	18.7	20.3
C	15.4	15.7	15.7	19.3
D	3.6	7.4	7.4	7.3
E	4.2	4.5	4.5	6.2
F	5.0	5.1	5.1	6.9
G	5.0	5.0	1.4	5.0

Parts Drawing - Model 3375P-05T4

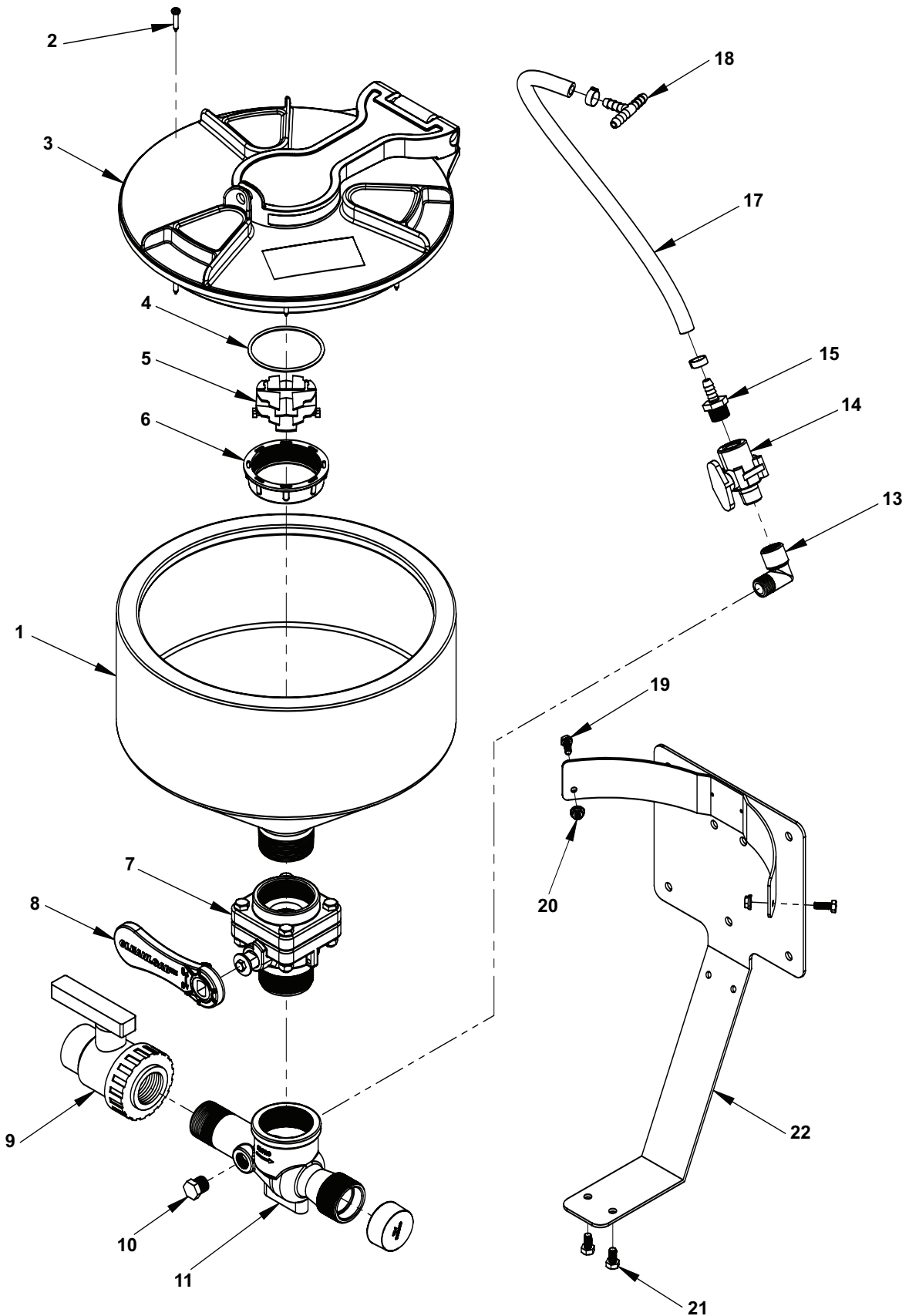

Parts List - Model 3375P-05T4

Ref. No.	Qty. Req'd.	Part No.	Description
1	1	1530-0018	Tank, 4.9 Gallon
2	8	2210-0133	Screw, Tapping
3	1	TLA-0004	TL/Ring S/A 12" Hinged
4	1	TLP-0010	O-Ring, Breather
5	1	TLP-0008	Labyrinth Breather
6	1	TLP-0012	Nut, Breather
7	1	9950-0043	Ball Valve Stubby 2"
8	1	2800-0027	Handle, Cleanload Ball Valve
9	1	9951-2125N	Ball Valve PP 1-1/4" NPT
10	1	3F12	1/2" MNPT PP Hex Plug
11	1	3371-0034S	Eductor, Machined Complete
13	1	3SE12	1/2" FNPT X 1/2" MNPT Street Elbow
14	1	3305-0112	Valve, 1/2" NPT (M) X 1/2" NPT (F)
15	1	3A1238	1/2" MNPT X 3/8" Hose Barb - Poly.
17	1	2900-0080	Hose - 3/8" x 18" Braided
18	1	3T38	HB PP Tee, 3/8"
19	2	2210-0134	Screw
20	2	2250-0109	Nut, Serrated Flange Lock
21	2	2210-0003	Screw Hex Head
22	1	1510-0107	Frame For Cleanload Mini

Parts Drawing - Model 3375P-05T5

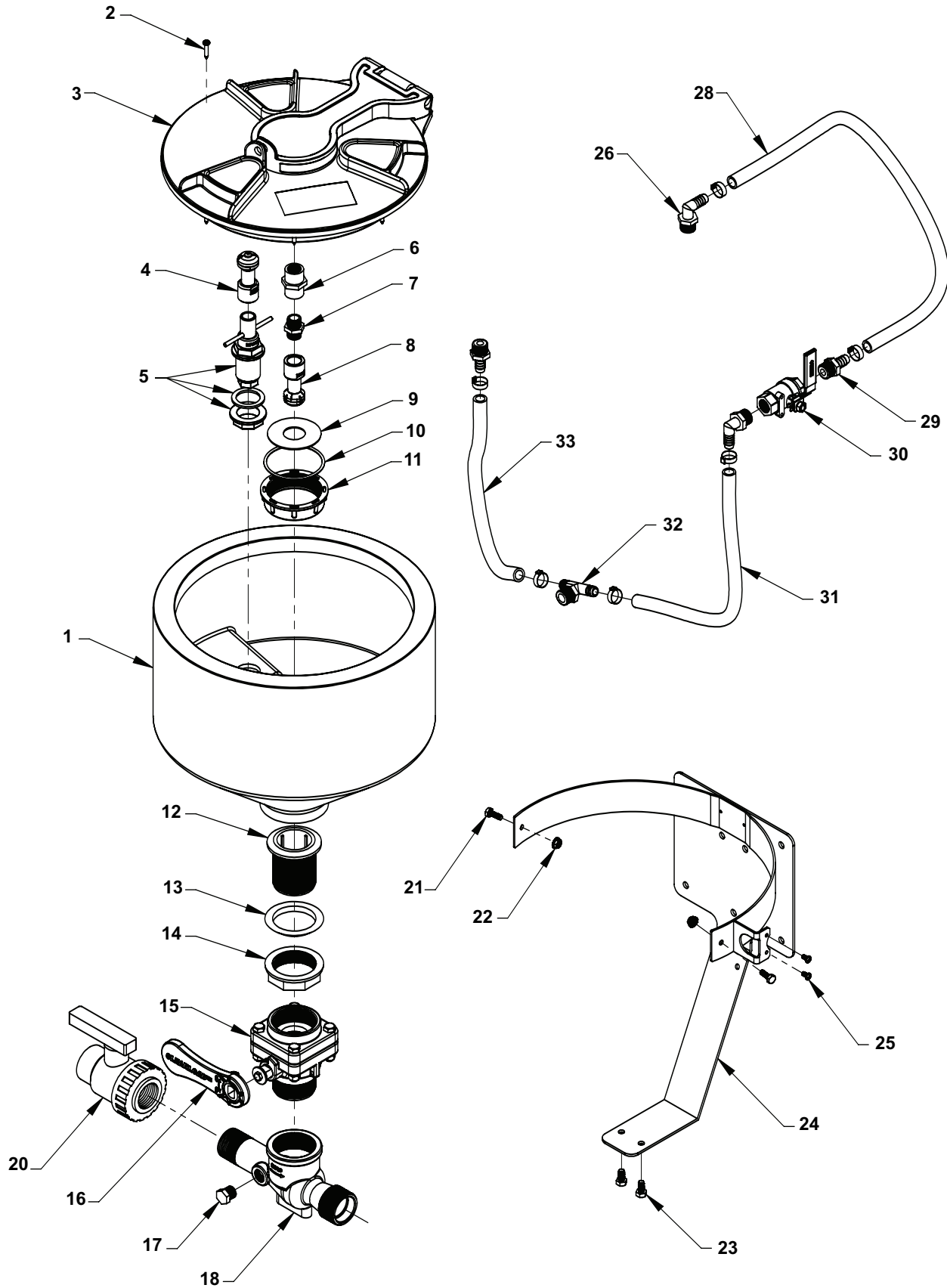

Parts List - Model 3375P-05T5

Ref. No.	Qty. Req'd.	Part No.	Description
1	1	1530-0016	Tank, 5.8 Gallon Black
2	8	*	Screw, Tapping
3	1	*	TL/Ring S/A 12" Hinged
4	1	PC1/2F-36075	ProClean Container Nozzle
5	1	PV1/2F1/2M-MA	ProClean Push Valve Assembly
6	1	*	1/2" x 1/2" FNPT Coupler
7	1	*	1/2" x 1/2" Thread Nipple
8	1	PC1/2F-235120	ProClean Tank Wash Nozzle
9	1	1410-0129	Retainer, Splash
10	1	*	O-Ring, Breather
11	1	*	Nut, Breather
12	1	220070	2" Tank Outlet
13	1	2270-0119R	Gasket, Tapered
14	1	205070	2" Lock Ring Nut
15	1	9950-0043	Ball Valve Stubby 2"
16	1	2800-0027	Handle, Cleanload Ball Valve
17	1	3F12	1/2" MNPT PP Hex Plug
18	1	3371-0034S	Eductor, Machined Complete
20	1	9951-2125N	Ball Valve PP 1-1/4" NPT
21	2	2210-0134	Screw
22	2	2250-0109	Nut, Serrated Flange
23	2	2210-0003	Screw Hex Head
24	1	1510-0103	Frame, Cleanload 5.8 Gal.
25	2	2210-0132	Screw, Phillips Head S. S.
26	2	*	1/2" MNPT X 1/2" HB Poly Elbow
28	1	2900-0073	Hose, Tank Rinse 1/2x15"
29	2	3A12	1/2" MNPT X 1/2" HB - Poly.
30	1	78-12	1/2" FNPT 316 SS Ball Valve
31	1	2900-0074	Hose, Valve Feeder 1/2x24"
32	1	3T12T	HB Tee, 1/2" MNPT to 1/2" HB
33	1	2900-0072	Hose, Bottle Rinse 1/2x15"

***No. 3430-0806 12" Lid Kit** consists of:

(8) Ref. No. 2 Tapping Screws, (1) Ref. 3 12-inch Hinged TL/Ring S/A, (1) Ref. 6 Coupler, (1) Ref. 7 Nipple, (1) Ref. 10 Breather O-ring, (1) Ref. 11 Breather Nut, and (2) Poly Elbows.

Parts Drawing - Model 3375P-05T5-01

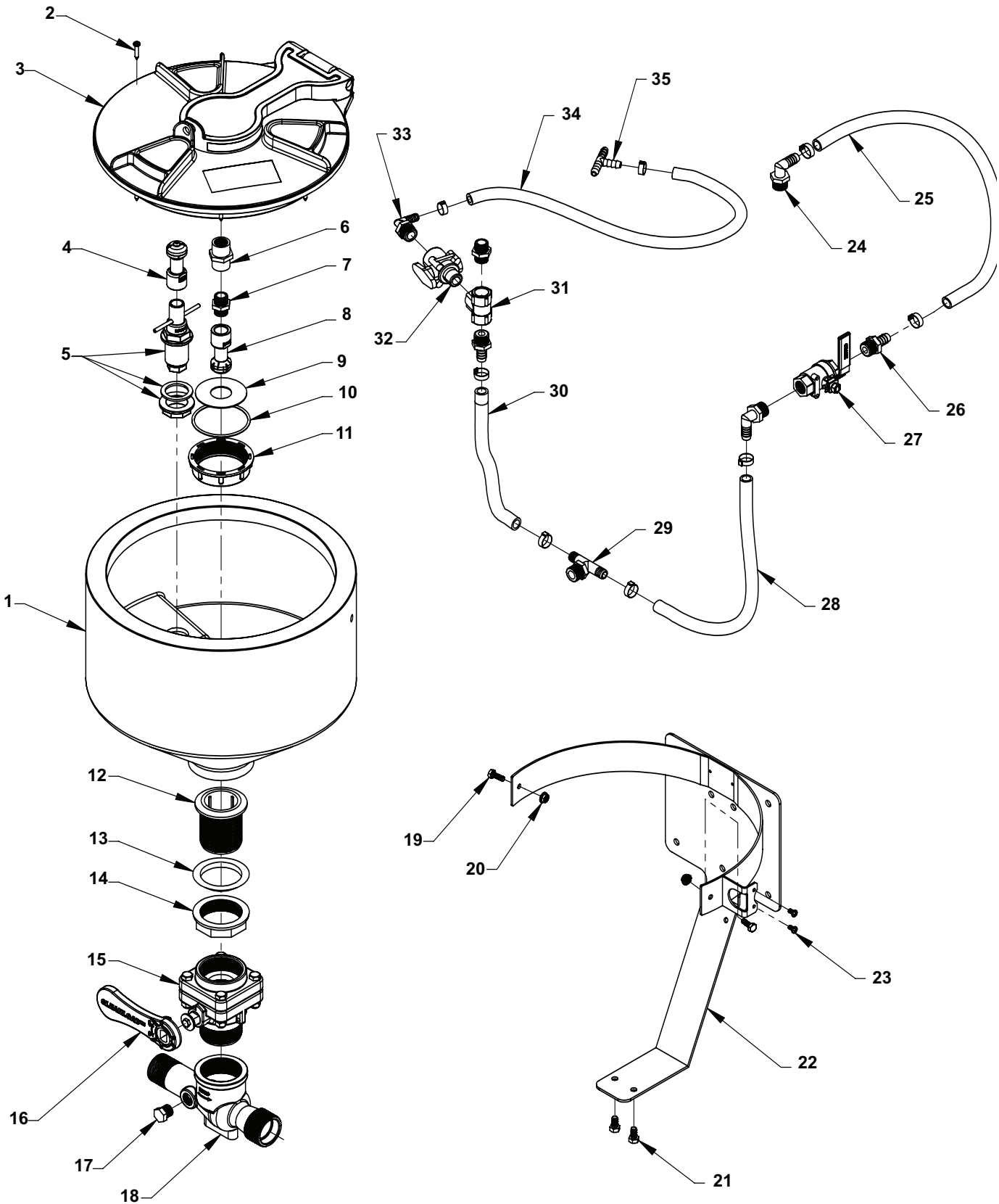

Parts List - Model 3375P-05T5-01

Ref. No.	Qty. Req'd	Part No.	Description
1	1	1530-0016	Black Cleanload Tank 5.8 Gallon
2	8	*	Screw, Tapping
3	1	*	TL/Ring S/A 12" Hinged
4	1	PC1/2F-36075	ProClean Container Nozzle
5	1	PV1/2F1/2M-MA	ProClean Push-Valve Assembly
6	1	*	1/2" X 1/2" FNPT Coupler
7	2	*	1/2" X 1/2" Thread Nipple
8	1	PC1/2F-235120	ProClean Tank Wash Nozzle
9	1	1410-0129	Retainer, Splash
10	1	*	O-Ring, Breather
11	1	*	Nut, Breather
12	1	220070	2" Tank Outlet
13	1	2270-0119R	Gasket, Tapered
14	1	205070	2" Lock Ring Nut
15	1	9950-0043	Ball Valve Stubby 2"
16	1	2800-0027	Handle, Cleanload Ball Valve
17	1	3F12	1/2 MNPT PP Hex Plug
18	1	3371-0034S	Eductor-Machined Complete
19	2	2210-0134	Screw
20	2	2250-0109	Nut, Serrated Flange Lock
21	2	2210-0003	Screw Hex Head
22	1	1510-0103	Frame Cleanload 5.8 Gallon
23	2	2210-0132	Screw, Phillips Head S. S.
24	2	*	1/2" MNPT X 1/2" HB Poly Elbow
25	1	2900-0073	Hose, Tank Rinse 1/2 X 20"
26	2	3A12	1/2" MNPT X 1/2" HB Polypro
27	1	78-12	1/2" FNPT 316 SS Ball Valve
28	1	2900-0074	Hose, Valve Feeder 1/2 X 24"
29	1	3T12T	1/2MNPT-1/2"HB-1/2HB TEE
30	1	2900-0075	Hose, Tank Rinse 1/2" X 13"
31	1	3TT12	1/2" FNPT "T" Poly Pro
32	1	3305-0112	Valve, 1/2" NPT (M) X 1/2" NPT (F)
33	1	3EL1238	1/2" MNPT x 3/8" HB Poly Elbow
34	1	2900-0095	Hose, EPDM 3/8" Dia. X 26" Long
35	1	3T38	3/8" HB PP Tee

***No. 3430-0806 12" Lid Kit** consists of:

(8) Ref. No. 2 Tapping Screws, (1) Ref. 3 12-inch Hinged TL/Ring S/A, (1) Ref. 6 Coupler, (1) Ref. 7 Nipple, (1) Ref. 10 Breather O-ring, (1) Ref. 11 Breather Nut, and (2) Poly Elbows.

Parts Drawing - Model 3375P-05T7

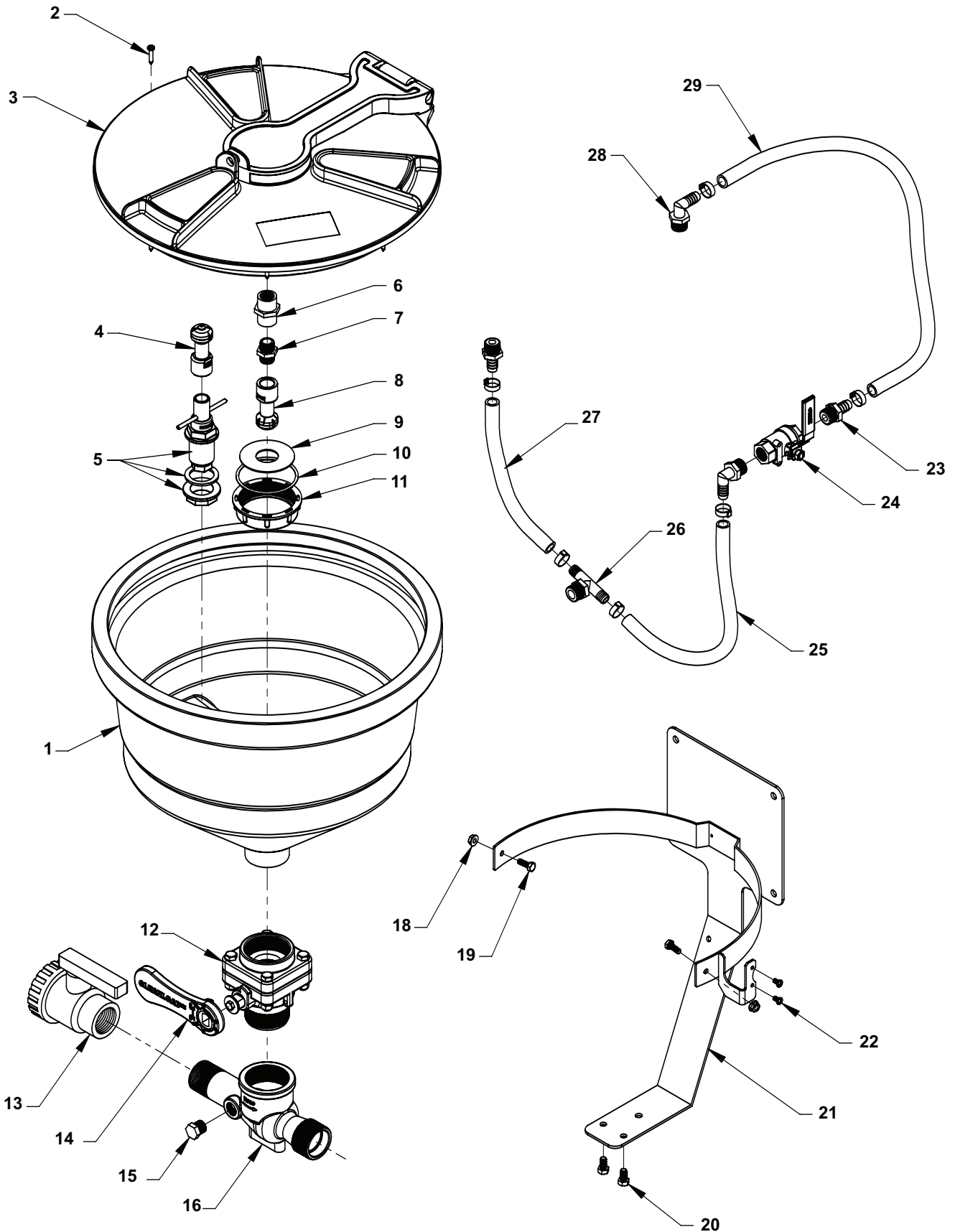

Parts List - Model 3375P-05T7

Ref. No.	Qty. Req'd.	Part No.	Description
1	1	1530-0029	Tank Cleanload - 7.0
2	8	*	Screw, Tapping
3	1	*	TL/Ring S/A 16" Hinged
4	1	PC1/2F-36075	ProClean Container Nozzle
5	1	PV1/2F1/2M-MA	ProClean Push-Valve Assembly
6	1	*	1/2" X 1/2" FNPT Coupler
7	1	*	1/2" X 1/2" Thread Nipple
8	1	PC1/2F-235120	ProClean Tank Wash Nozzle
9	1	1410-0129	Retainer-Splash
10	1	*	O-Ring, Breather
11	1	*	Nut, Breather
12	1	9950-0043	Ball Valve Stubby 2"
13	1	9951-2125N	Ball Valve PP 1-1/4 NPT
14	1	2800-0027	Handle-Cleanload Ball Valve
15	1	3F12	1/2 MNPT PP Hex Plug
16	1	3371-0034S	Eductor-Machined Complete
18	2	2250-0077	Nut
19	2	2210-0134	Screw
20	2	2210-0003	Screw Hex Head
21	1	1510-0119	Frame, Cleanload Back Mount
22	2	2210-0132	Screw, Phillips Head S. S.
23	2	3A12	1/2" MNPT X 1/2" HB Polypro
24	1	78-12	1/2" FNPT 316 SS Ball Valve
25	1	2900-0073	Hose, Tank Rinse 1/2 X 20"
26	1	3T12T	1/2MNPT-1/2"HB-1/2HB TEE
27	1	2900-0072	Hose, Bottle Rinse 1/2 X 15"
28	2	*	1/2" MNPT X 1/2" HB Poly Elbow
29	1	2900-0074	Hose, Valve Feeder 1/2 X 24"

***No. 3430-0807 16" Lid Kit** consists of:

(8) Ref. No. 2 Tapping Screws, (1) Ref. 3 16-inch Hinged TL/Ring S/A, (1) Ref. 6 Coupler, (1) Ref. 7 Nipple, (1) Ref. 10 Breather O-ring, (1) Ref. 11 Breather Nut, and (2) Ref. 8 Poly Elbows.

Limited Warranty on Hypro/SHURflo Agricultural Pumps & Accessories

Hypro/SHURflo (hereafter, "Hypro") agricultural products are warranted to be free of defects in material and workmanship under normal use for the time periods listed below, with proof of purchase.

- Pumps: one (1) year from the date of manufacture, or one (1) year of use. This limited warranty will not exceed two (2) years, in any event.
- Accessories: ninety (90) days of use.

This limited warranty will not apply to products that were improperly installed, misapplied, damaged, altered, or incompatible with fluids or components not manufactured by Hypro. All warranty considerations are governed by Hypro's written return policy.

Hypro's obligation under this limited warranty policy is limited to the repair or replacement of the product. All returns will be tested per Hypro's factory criteria. Products found not defective (under the terms of this limited warranty) are subject to charges paid by the returnee for the testing and packaging of "tested good" non-warranty returns.

No credit or labor allowances will be given for products returned as defective. Warranty replacement will be shipped on a freight allowed basis. Hypro reserves the right to choose the method of transportation.

This limited warranty is in lieu of all other warranties, expressed or implied, and no other person is authorized to give any other warranty or assume obligation or liability on Hypro's behalf. Hypro shall not be liable for any labor, damage or other expense, nor shall Hypro be liable for any indirect, incidental or consequential damages of any kind incurred by the reason of the use or sale of any defective product. This limited warranty covers agricultural products distributed within the United States of America. Other world market areas should consult with the actual distributor for any deviation from this document.

Return Procedures

All products must be flushed of any chemical (ref. OSHA section 1910.1200 (d) (e) (f) (g) (h)) and hazardous chemicals must be labeled/tagged before being shipped* to Hypro for service or warranty consideration. Hypro reserves the right to request a Material Safety Data Sheet from the returnee for any pump/product it deems necessary. Hypro reserves the right to "disposition as scrap" products returned which contain unknown fluids. Hypro reserves the right to charge the returnee for any and all costs incurred for chemical testing, and proper disposal of components containing unknown fluids. Hypro requests this in order to protect the environment and personnel from the hazards of handling unknown fluids.

Be prepared to give Hypro full details of the problem, including the model number, date of purchase, and from whom you purchased your product. Hypro may request additional information, and may require a sketch to illustrate the problem.

Contact Hypro Service Department at 800-468-3428 to receive a Return Merchandise Authorization number (RMA#). Returns are to be shipped with the RMA number clearly marked on the outside of the package. Hypro shall not be liable for freight damage incurred during shipping. Please package all returns carefully. All products returned for warranty work should be sent **shipping charges prepaid** to:

HYPRO
Attention: Service Department
375 Fifth Avenue NW
New Brighton, MN 55112

For technical or application assistance, call the **Hypro Technical/Application number: 800-445-8360**, or send an email to: **technical@hypropumps.com**. To obtain service or warranty assistance, call the **Hypro Service and Warranty number: 800-468-3428**; or send a fax to the **Hypro Service and Warranty FAX: 651-766-6618**.

*Carriers, including U.S.P.S., airlines, UPS, ground freight, etc., require specific identification of any hazardous material being shipped. Failure to do so may result in a substantial fine and/or prison term. Check with your shipping company for specific instructions.