

ARAG[®] Modular Manual Valve

Operating Instructions and Parts Manual

Description

Hypro/ARAG Manual Modular Controls are designed for agricultural and industrial spraying of a variety of fluids. These direct-acting valves can be used for pressure control or boom section on/off control. The modular

design reduces plumbing and allows for easy service of components. These valves work well with roller, diaphragm and centrifugal pumps.

463051 Manual Boom Section Valve

Features:

- Each section delivers 12 gpm with a 7 psi pressure drop
- Maximum pressure: 290 psi
- Fiberglass-reinforced nylon valve bodies with modular design
- Viton[®] seals
- 1/2" hose barb outlet
- Replaceable valve seats
- 3/4" hose barb
- Dimensions: width 2.5", height 8.4", length 4"



Part # 463051

463061 Manual Boom Section Valve with Bypass

Metered bypass valves offer 3-way valve control to maintain a more consistent system pressure with valves in the "on" or "off" position. The metering valve is adjusted depending upon the nozzle number and quantity per section.

Features:

- Each section delivers 12 gpm with a 7 psi pressure drop
- Maximum pressure: 290 psi
- Fiberglass-reinforced nylon valve bodies with modular design
- Viton[®] seals
- Replaceable valve seats
- 3/4" hose barb
- Dimensions: width 2.5", height 9.3", length 4.5"



Part # 463061

Description (continued)

463080N Pressure Regulating Valve



Features:

- Bypasses the excess flow and maintains a constant line pressure
- Fiberglass-reinforced nylon body
- Internal parts in Delrin® and 303 stainless steel
- Viton® seals
- Maximum pressure: 290 psi
- 3/4" hose barb
- Dimensions: width 2.5", height 8", length 2.5"

463070N Manual Proportional Flow Control Valve



Features:

- Adjusts flow proportionally to control spray pressure
- Fiberglass-reinforced nylon body
- Internal parts in Delrin
- Maximum pressure: 580 psi
- 3/4" hose barb
- Dimensions: width 2.5", height 8", length 2.5"

General Safety Information

For roller and diaphragm pumps, use a pressure relief device on the discharge side of the pump to prevent damage from pressure buildup when the pump discharge is blocked or otherwise closed, and the power source is still running.

1. **WARNING: Never pump flammable or explosive fluids such as gasoline, fuel oil, kerosene, etc. Never use in explosive atmospheres. The valve should be used only with liquids compatible with the valve component materials. Failure to follow this warning can result in personal injury and/or property damage and will void the product warranty.**
2. Never pump at pressures higher than the maximum recommended pressure.
3. Never pump liquids at temperatures higher than the maximum recommended temperatures (140° F / 60° C).
4. Disconnect power before servicing.
5. Release all pressure within the system before servicing any component.
6. Drain all liquids from the system before servicing any component.
7. Check all hoses for weak or worn condition before each use. Make certain that all connections are tight and secure.
8. Periodically inspect the valve and the system components. Perform routine maintenance as required (see Maintenance section).
9. Use only pipe, hose and fittings rated for the maximum psi rating of the valve.

System Installation

NOTE: Use only pipe, fittings, accessories, hose, etc. rated for the maximum pressure rating of the valve.

1. Use the supplied brackets for mounting.
2. Avoid unnecessary restrictions in the line; such as elbows, check valves, and all extraneous curves and bends.
3. Avoid using looped sections of tubing or pipe which might permit air to become trapped.
4. Selection of the right type and size of hose is vital to good performance.
5. Never attach an agitator or any restriction to a bypass line of a pressure relief device because system damage may occur.

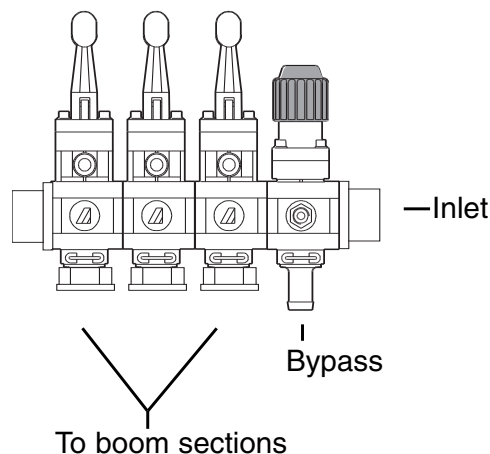

Hazardous Substance Alert

1. Always drain and flush valve before servicing or disassembling for any reason.
2. Always drain and flush valve prior to returning unit for repair.
3. Never store valve containing hazardous chemicals.
4. Before returning valve for service/repair, drain out all liquids and flush unit with neutralizing liquid. Then, drain the valve. Attach tag or include written notice certifying that this has been done. Please note that it is illegal to ship or transport any hazardous chemicals without United States Environmental Protection Agency Licensing.

Maintenance

1. Flush system with clean water after chemical use.
2. In climates where freezing occurs, drain fluids after use to avoid damage, or store with antifreeze.
3. Periodically check valve assembly for leaks. Replace parts as needed.
4. Lubricate o-rings before assembly.

Parts Breakdown

BOOM SECTION VALVE

PART NUMBER 463051

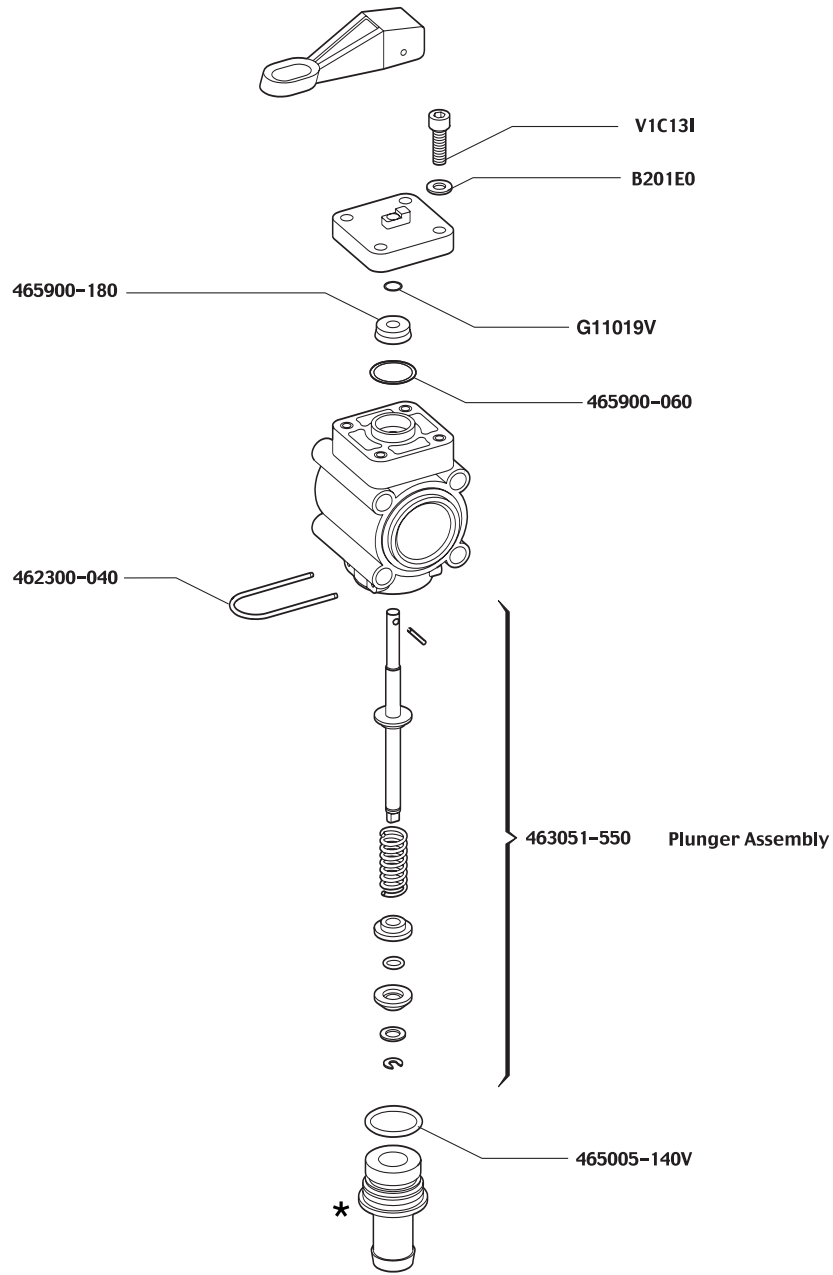

*** Outlet ports with Viton O-Rings**

Part Number	Hose Barb	FNPT
463001-110-1	3/8"	-
463001-113-1	1/2"	-
463001-119-1	3/4"	-
463001-275N-1	-	3/4"

Parts Breakdown

BOOM SECTION VALVE WITH BYPASS

PART NUMBER 463061

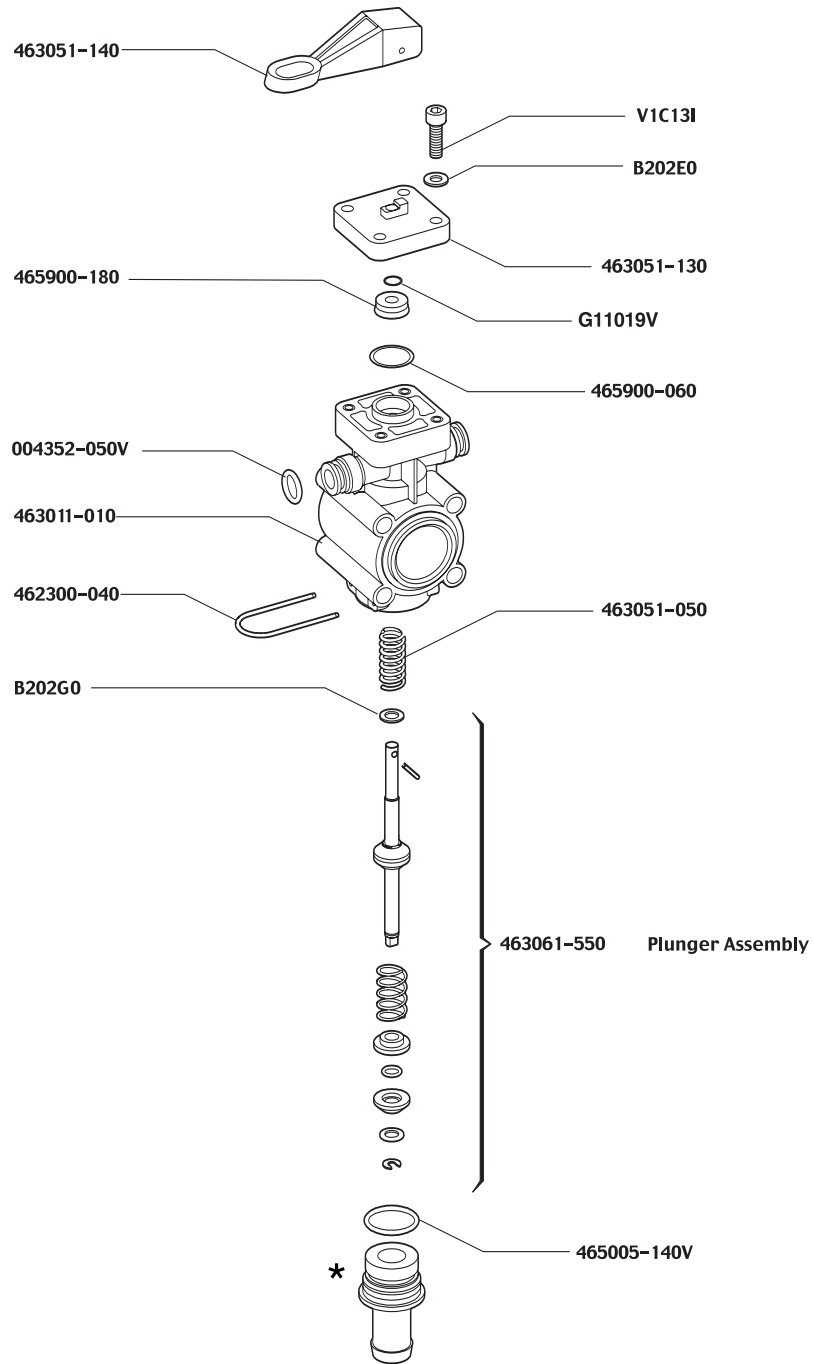

* Outlet ports with Viton O-Rings

Part Number	Hose Barb	FNPT
463001-110-1	3/8"	-
463001-113-1	1/2"	-
463001-119-1	3/4"	-
463001-275N-1	-	3/4"

Parts Breakdown

PRESSURE REGULATING CONTROL VALVE PART NUMBER 463080N

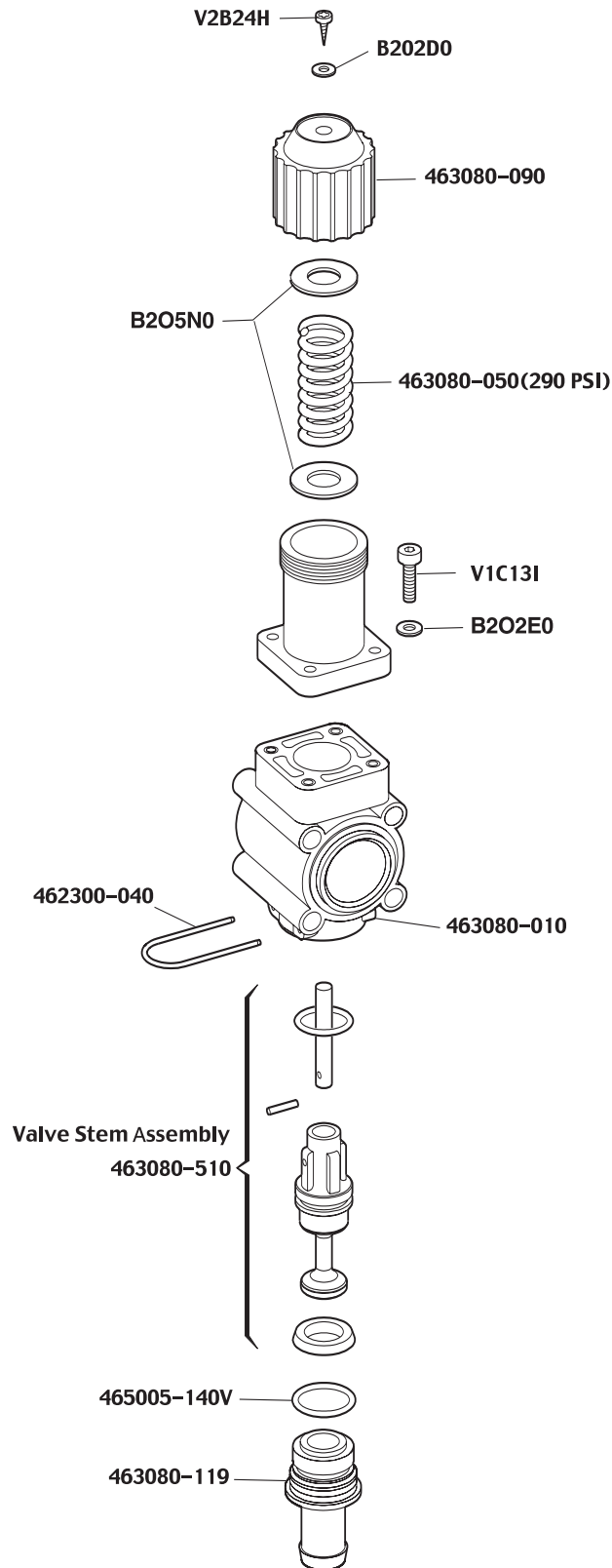

PROPORTIONAL CONTROL VALVE PART NUMBER 463070N

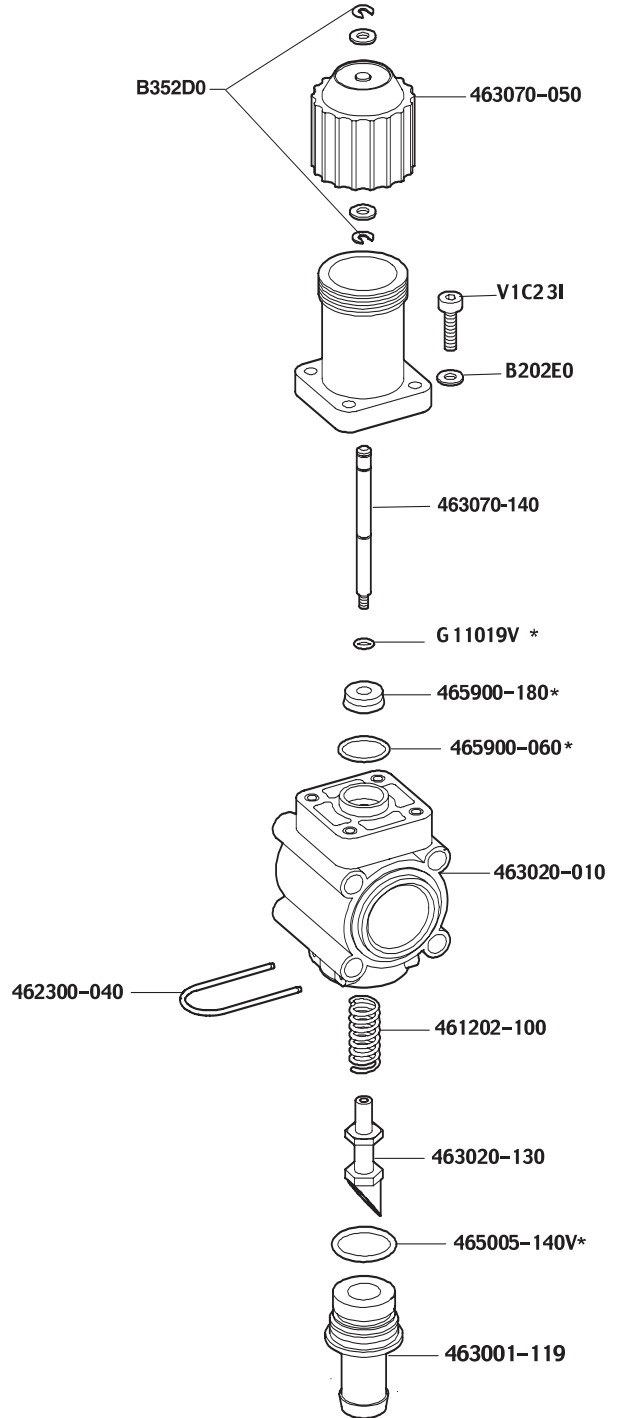

* = 463020-500 Gasket set

Manifold Assemblies



Part Number

MV-463051-1

3/4" FNPT inlet, 3/4" hose barb outlets.



Part Number

MV-463051-3

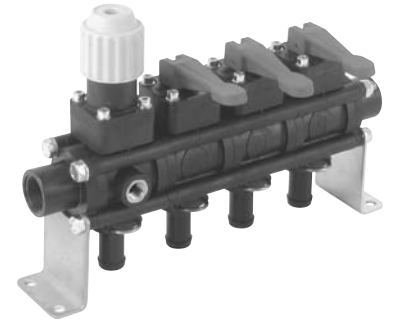

Part Number

MV-463051-3-MPR

Includes pressure regulating valve

Manifold Assemblies with Bypass



Part Number

MV-463061-1

3/4" FNPT inlet, 3/4" hose barb outlets.



Part Number

MV-463061-3

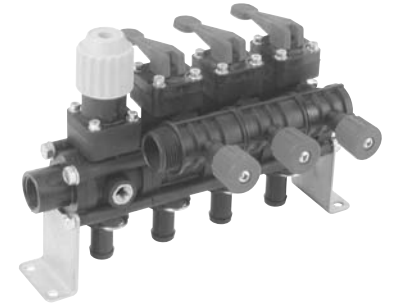

Part Number

MV-463061-3-MPR

Includes pressure regulating valve

463 Series Manifold Mounting Kits

Boom Manifold Mounting Kits

Brackets can be rotated into any 90° position. Kit includes two mounting brackets, four proper length bolts, washers, lock nuts, and Viton® o-rings as required.



PART NO.	DESCRIPTION
B12151	Lock Nut
B201H1	Washer
463011-100	Mounting Bracket
G10071V	O-ring

Galvanized Part Number	Boom Sections
463000-910	1
463000-920	2
463000-930	3
463000-940	4
463000-950	5
463000-960	6
463000-970	7
463000-980	8
463000-990	9

Limited Warranty on Hypro Products

Hypro warrants to the original purchaser of its products (the "Purchaser") that such products will be free from defects in material and workmanship under normal use for the period of one (1) year for all Arag controls, which includes all consoles, wiring, manual and electrical valves. "Normal use" does not include use in excess of recommended maximum speeds, pressures, vacuums and temperatures, or use requiring handling of fluids not compatible with component materials, as noted in Hypro product catalogs, technical literature, and instructions. This warranty does not cover freight damage, freezing damage, normal wear and tear, or damage caused by misapplication, fault, negligence, alterations, or repair that affects the performance or reliability of the product.

THIS WARRANTY IS EXCLUSIVE. HYPRO MAKES NO OTHER WARRANTY, EXPRESS OR IMPLIED, INCLUDING BUT NOT LIMITED TO ANY WARRANTY OF MERCHANTABILITY OR FITNESS FOR A PARTICULAR PURPOSE.

Hypro's obligation under this warranty is, at Hypro's option, to either repair or replace the product upon return of the entire product to the Hypro factory in accordance with the return procedures set forth below. **THIS IS THE EXCLUSIVE REMEDY FOR ANY BREACH OF WARRANTY.**

IN NO EVENT SHALL HYPRO BE LIABLE FOR ANY INCIDENTAL OR CONSEQUENTIAL DAMAGES OF ANY KIND, WHETHER FOR BREACH OF ANY WARRANTY, FOR NEGLIGENCE, ON THE BASIS OF STRICT LIABILITY, OR OTHERWISE.

Return Procedures

All products *must* be flushed of any chemical (ref. OSHA Section 0910.1200 (d)(e)(f)(g)(h)) and hazardous chemicals *must* be labeled before being shipped* to Hypro for service or warranty consideration. Hypro reserves the right to request a Material Safety Data sheet from the Purchaser for any pump or product Hypro deems necessary. Hypro reserves the right to "disposition as scrap" pumps or products returned which contain unknown substances, or to charge for any and all costs incurred for chemical testing and proper disposal of components containing unknown substances. Hypro requests this in order to protect the environment and personnel from the hazards of handling unknown substances.

For technical or application assistance, call the **Hypro Technical/Application number: 1-800-445-8360. To obtain service or warranty assistance, call the Hypro Service and Warranty number: 1-800-468-3428; or call the Hypro Service and Warranty FAX: (651) 766-6618.**

Be prepared to give Hypro full details of the problem, including the following information:

1. Model number and the date and from whom you purchased your product.
2. A brief description of the product problem.

Hypro may request additional information, and may require a sketch to illustrate the problem. Contact the factory to receive a return material authorization before sending the product. All products returned for warranty work should be sent shipping charges prepaid to:

HYPRO
Attention: Service Department
375 Fifth Avenue NW
New Brighton, Minnesota 55112

* Carriers, including U.S.P.S., airlines, UPS, ground freight, etc., require specific identification of any hazardous materials being shipped. Failure to do so may result in a substantial fine and/or prison term. Check with your shipping company for specific instructions.



Pentair

SPRAY & INJECTION TECHNOLOGIES GROUP

375 Fifth Avenue NW • New Brighton, MN 55112

Phone: (651) 766-6300 • 800-424-9776 • Fax: 800-323-6496

www.hypropumps.com