



General Safety Information

WARNING: Do not pump flammable or explosive fluids such as Gasoline, Fuel Oil, Kerosene, etc. Do not use in explosive atmospheres. The pump should be used only with liquids that are compatible with the pump component materials. Failure to follow this Warning can result in Personal Injury and/or Property Damage and Will Void the Product Warranty.

1. DO NOT EXCEED recommended speed, pressure and temperature (120 degrees F) for pump and equipment being used.
2. BEFORE SERVICING, drain all liquids from the system and flush. Remove the spark plug wire from the spark plug before servicing the pump or engine.
3. Secure the discharge lines before starting the pump. An unsecured line may whip, causing personal injury and/or property damage.
4. Check hose for weak or worn condition before each use. Make certain that all connections are tight and secure.

5. Periodically inspect the pump and the system components. Perform routine maintenance as required (see Maintenance section).
6. Protect pump from freezing conditions by draining liquid and pumping a permanent-type automobile antifreeze containing a rust inhibitor through the system, coating the pump interior. A 50% mixture with water is recommended.
7. Do not operate a gasoline engine in an enclosed area. Be sure the area is well ventilated.

WARNING: Gasoline is a highly combustible fuel. The improper use, handling, or storage of Gasoline can be dangerous. Never touch or fill a hot engine.

8. Use only pipe, hose and fittings rated for the maximum psi rating of the pump.
9. Do not use these pumps for pumping water or other liquids for human or animal consumption.

Plumbing Installation

IMPORTANT

For best possible performance and continuous, satisfactory operation, read these instructions before installing your new pump. Should service be required, this manual can be a valuable guide. It should be kept near the installation for ready reference.

Preliminary to Mounting

Before setting up the pump for operation, check to see that the motor and pump turn freely by hand. If it cannot be turned over by pulling on the recoil starter, open casing to check for obstructions lodged in pump.

Basket Strainer

A basket strainer is to be used when transferring solutions that may contain debris and solids which could become lodged in the pump or damage the impeller. Because of the high flow capacity of this pump, unknown debris could be siphoned off the bottom of the tank. Install the strainer on the suction side of the pump whenever possible to avoid pump damage.

INSTALLATION

LOCATION

Place unit as close to water source as possible to minimize suction lift, obtain the best pumping performance, and aid in priming.

For permanent installation, mount unit on a foundation that will support the weight of the pump and engine and also provide stability while the pump is running. For most permanent installations, it is advisable to bolt unit directly to foundation.

NOTICE: Settling and/or shifting during operation can cause piping to place excessive strain on the pump and may damage pump case. Set pump on hard level surface. Non-level surfaces may cause the oil sensor in the engine to shut down the unit.

SUCTION CONNECTION

Connect either rigid pipe or flexible suction hose to pump suction. If hose is selected, hose must be rated to hold the suction vacuum and prevent collapse while the pump is running.

Make the suction line a continuous rise from the water source to the pump. High spots can trap air and also make priming difficult. Make sure all connections are tight and free of air leaks.

NOTICE: Suction pipe or hose must be at least as large as the pump suction inlet in order for the pump to operate properly. If the inlet line is longer than approximately 6 feet, use the next size larger line.

Minimum depth for the suction inlet is determined by the diameter of the suction line.

DISCHARGE CONNECTIONS

Your pump is equipped with a single port discharge. Select the appropriate size for the application. Install a "T" to allow easy priming of the pump without disconnecting the piping, or by using the priming plug on the housing.



Warning

Hazardous Suction

Can trap persons against suction inlet.

Always use strainer on suction hose to prevent entrapment.



Hazardous Substance Alert

Please Note: It is illegal to ship or transport any hazardous chemicals without United States Environmental Protection Agency Licensing.

1. Always drain and flush pumps before servicing or disassembling for any reason.

2. Before returning unit for repair, drain out all liquids and flush unit with neutralizing liquid. Then, drain the pump. Attach a tag or include a written notice certifying that this has been done.
3. Never store pumps containing hazardous chemicals.

Operation and Maintenance

Preparations Before Starting the Engine

1. **Engines come from factory without oil. Please fill with oil prior to starting!**
2. Fuel: Check fuel level in tank, and do not over fill. Use fresh, clean automotive fuel. **Note: DO NOT FILL FUEL TANK WHEN ENGINE IS RUNNING.**
3. Engine Oil: Before checking or refilling with engine oil, make sure the engine is stopped and placed on a stable, level surface. Use oil recommended for ambient air temperatures that the engine will be running at. See chart below. Change oil after the first 20 hours and every 100 hours thereafter.

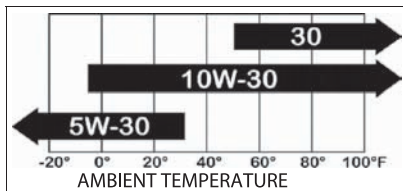

4. Priming Water: **IMPORTANT: PUMP MUST NOT BE RUN DRY.** On self-priming pumps, only the chamber needs to be filled with liquid. The pump must not run unless the priming chamber is completely filled with liquid because there is a danger of damaging the mechanical seal, which depends on the liquid for its lubrication.

Self-priming models can be primed by removing the filler cap located at the top of the pump where the discharge line is mounted to the pump, and filling the priming chamber with liquid. After use, the priming chamber should be flushed and drained to avoid chemical corrosion and damage from freezing. Drain by removing the lower drain plug located at the bottom of the casing.

Starting the Pump

IMPORTANT: Before starting engine, be sure the priming chamber is filled with liquid and the discharge hose is secure.

1. Turn engine switch located by recoil starter to ON position.
2. Turn the fuel cock to ON.
3. Push the throttle lever to a slightly open position.

4. Operation of choke lever.
When engine is cold:
In cold weather, start engine with choke in fully closed position.
In warm weather, start engine with choke in half-closed position.
When engine is warm:
Start engine with choke in fully open position.
5. Start engine by pulling recoil starter out quickly and forcefully. Repeat pulling until the engine starts.

Operation of the Pump

1. Idle the engine for 3 to 5 minutes to warm it up.
2. Open the throttle lever to the upper zone after engine has warmed up.
3. Once the pump has primed, you will note a load on the engine; adjust rpms to proper speed for your pumping application.

Stopping the Pump

1. Stop pump for a short time:
Run engine throttled all the way down (fully to the right). Turn engine switch to OFF position.
2. Stopping pump for storage:
Turn fuel cock to OFF position instead of turning the engine switch off.
Let the engine idle for 2 to 3 minutes until fuel in carburetor is depleted and engine stops. If a valve is installed on the discharge hose, you may run pump with valve closed during this procedure.
Note: Pump must not be run dry. Make sure there is water in the priming chamber.

Storage

1. Drain pump. Flush pump after use.
One of the most common causes for faulty pump performance is gumming or corrosion inside the pump. Flush the pump and entire system with a solution that will chemically neutralize the liquid pumped. Mix according to the manufacturer's directions. This will dissolve most residues remaining in the pump, leaving the inside of the pump clean and ready for use.
2. Drain all the fuel from the fuel tank, fuel lines, and filter.
3. Store pump in a clean, dry environment.

Assembly Instructions

INITIAL ASSEMBLY – gas engine, C-faced electric motor, or pedestal mount

Note: Prior to assembly, visually inspect pump outlet for impeller spacer. Pumps are supplied with a strip of plastic banding inserted into the pump outlet and across the impeller face to ensure proper impeller spacing. If the banding is in place, proceed to step 10. If banding is missing, begin with step 1. (Figure 1)

1. Remove two-bolt clamp from pump shaft. (Figure 2)
2. Remove (6) nuts and lock washers holding adapter to pump. (Figure 3)

Note: When removing adapter, be careful not to damage paper gasket between adapter and pump.

Note: Mechanical seal will be exposed after adapter is removed. Be careful not to damage seal faces.

3. Gently pry the adapter flange off using a pry bar against tabs on the adapter. (Figure 4)
4. Leave paper gasket on pump over mounting studs. If gasket is damaged, replace with a new one. Gasket sealant is not required.
5. Remove impeller, drive sleeve, mechanical seal assembly.
6. Insert a shim between the impeller vanes and pump wear plate. A shim 1/2" wide and 0.035" to 0.040" (2" pump) / 0.060" to 0.066" (3" pump) is required. Plastic or steel banding can be used as a shim. Verify banding thickness prior to use. Place shim material into the pump through the outlet port. Shim material must lie across the wear plate. (Figure 5)
7. Reinstall impeller assembly ensuring the impeller vanes rest on the shim material.
8. Reinstall adapter flange over mounting studs.
9. Tighten (6) nuts and lock washers. (Figure 6)
 - A. 2" pump – 5/16 x 18 nut – 11 ft.-lbs./ 14.9 Nm torque.
 - B. 3" pump – 3/8 x 16 nut – 20 ft.-lbs./ 27.1 Nm torque.

Note: If impeller spacer is in place, start here.



Fig. 1



Fig. 2



Fig. 3

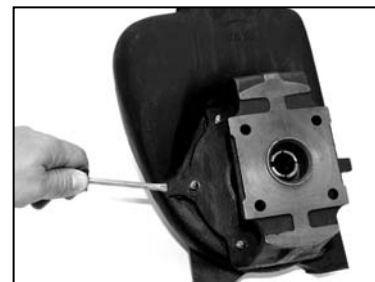

Fig. 4

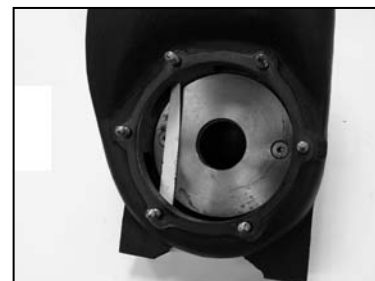

Fig. 5

Assembly Instructions

10. Install two-bolt clamp over drive sleeve. Be careful to ensure keyed portion of clamp sits in drive sleeve slot. Leave bolts and nuts finger tight. ***Some clamps may not have an integral key. (Figure 7)
11. Apply an anti-seize compound to engine, motor, or pedestal shaft.
12. Install gas engine, c-faced electric motor, or pedestal into pump drive sleeve. Align keyway of drive source with slot in drive sleeve. Do not rotate the pump shaft during assembly. This may cause the shim to become dislodged.
13. Install (4) mounting bolts between pump adapter and gas engine, electric motor, or pedestal. (Figure 8)
 - A. 2" pump – 5/16 x 24 screw – 11 ft.-lbs./ 14.9 Nm torque.
 - B. 3" pump – 3/8 x 16 screw – 20 ft.-lbs./ 27.1 Nm torque.
14. Alternately tighten clamp bolts to ensure even torque and balance.
 - A. 2" pump – 5/16 x 18 screw – 20 ft.-lbs./ 27.1 Nm torque.
 - B. 3" pump – 3/8 x 16 screw – 40 ft.-lbs./ 54.2 Nm torque.
15. Remove shim stock from pump outlet.
16. Pump and drive source should rotate freely.



Fig. 6

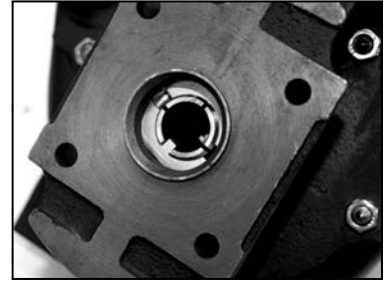

Fig. 7



Fig. 8

Disassembly Instructions

DISASSEMBLY – gas engine, C-faced electric motor, or pedestal mount

1. Remove two-bolt clamp and bolts. (Figure 9)
2. Remove (4) mounting bolts between pump adapter and engine, motor, or pedestal. (Figure 10)
3. Remove engine, motor, or pedestal. Drive source may need to be pried off. Use caution not to damage drive source or pump.
4. Remove (6) nuts and lock washers holding adapter to pump. (Figure 11)

Note: Mechanical seal will be exposed after adapter is removed. Be careful not to damage seal faces.

5. Gently pry the adapter flange off using a pry bar against tabs on the adapter. (Figure 12)
6. Remove impeller, drive sleeve, mechanical seal assembly.
7. Remove paper gasket and discard. Remove any gasket residue from adapter and pump faces.

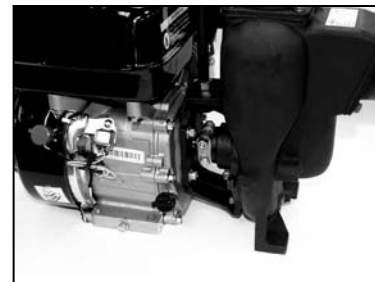

Fig. 9



Fig. 10



Fig. 11

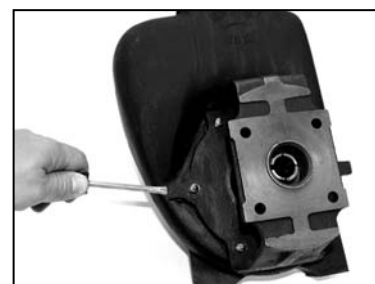

Fig. 12

Service Instructions

WEAR PLATE:

Inspect wear plate for excessive wear, surface grooves or impeller contact. Replace if needed. (Figure 13)

1. Remove two 3/8" stainless steel screws from wear ring. (Figure 14)

Note: Older models have acorn nuts and plastic washers on the front of the pump. If equipped, remove these first. (Figure 15)

2. Install new wear ring, making sure pump surface and ring are clean and the ring sits flat against the pump.
3. Reinstall stainless steel screws.
4. Reinstall plastic washers, and acorn nuts on older models.



Fig. 13



Fig. 14



Fig. 15

Service Instructions

MECHANICAL SEAL:

1. Remove seal and spring from impeller/drive sleeve assembly. (Figure 16)
2. Clean drive sleeve surface. Surface may be cleaned with 400 grit or higher sandpaper. If sleeve surface is worn, grooved or pitted, replace drive sleeve.

Note: Worn or damaged impeller/drive sleeve may cause the pump to under perform or become unbalanced, causing mechanical seal damage.

Note: Careful attention must be taken as to not scratch or damage the carbon face during installation.

3. Install new seal half onto drive sleeve.
4. Remove ceramic half from adapter flange.
5. Clean flange opening with a wire brush and/or sandpaper. (Figure 17)

Note: Careful attention must be taken as to not scratch or damage the ceramic face during installation.

6. Apply light lubrication to the outer rubber cup of the ceramic seal.
7. Install new seal half. Use your thumbs to apply light even pressure to set the cup in the adapter pocket. (Figure 18)



Fig. 16



Fig. 17

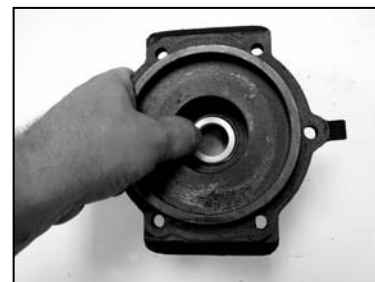

Fig. 18

Reassembly Instructions

REASSEMBLY:

1. Insert a shim between the impeller vanes and pump wear plate. A shim 1/2" wide and 0.035" to 0.040" (2" pump) / 0.060" to 0.066" (3" pump) is required. Plastic or steel banding can be used as a shim. Verify banding thickness prior to use. Place shim material into the pump through the outlet port. Shim material must lie across the wear plate. (Figure 19)

Note: Use caution not to damage ceramic and carbon seal faces while installing impeller assembly and adapter flange onto pump.

2. Install impeller assembly, ensuring the impeller vanes rest on the shim material.
3. Install new gasket onto pump over mounting studs. Gasket sealant is not required.
4. Install adapter flange over mounting studs.
5. Tighten (6) nuts and lock washers. (Figure 20)
 - A. 2" pump – 5/16 x 18 nut – 11 ft.-lbs./ 14.9 Nm torque.
 - B. 3" pump – 3/8 x 16 nut – 20 ft.-lbs./ 27.1 Nm torque.
6. Install two-bolt clamp over drive sleeve. Be careful to ensure keyed portion of clamp sits in drive sleeve slot. Leave bolts and nuts finger tight. ***Some clamps may not have an integral key. (Figure 21)
7. Apply an anti-seize compound to engine, motor, or pedestal shaft.
8. Install gas engine, c-faced electric motor, or pedestal into pump drive sleeve. Align keyway of drive source with slot in drive sleeve. Do not rotate the pump shaft during assembly. This may cause the shim to become dislodged.
9. Install (4) mounting bolts between pump adapter and gas engine, electric motor, or pedestal. (Figure 22)
 - A. 2" pump – 5/16 x 24 screw – 11 ft.-lbs./ 14.9 Nm torque.
 - B. 3" pump – 3/8 x 16 screw – 20 ft.-lbs./ 27.1 Nm torque.
10. Alternately tighten clamp bolts to ensure even torque and balance.
 - A. 2" pump – 5/16 x 18 screw – 20 ft.-lbs./ 27.1 Nm torque.
 - B. 3" pump – 3/8 x 16 screw – 40 ft.-lbs./ 54.2 Nm torque.
11. Remove shim stock from pump outlet.
12. Pump and drive source should rotate freely.



Fig. 19



Fig. 20

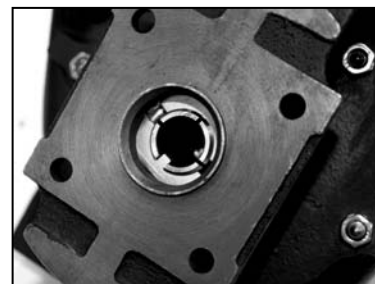

Fig. 21



Fig. 22

Service Instructions

RUNNING THE ENGINE

Refer to engine operation section of this manual for starting and operating instructions.

Pump performance varies depending on engine RPM. Refer to engine operation to adjust engine speed.

MAINTENANCE

PUMP LUBRICATION

Pump liquid end does not require any grease or oil for lubrication. The mechanical seal is lubricated by water when the pump is operating.

Troubleshooting Guide

SYMPTOM	PROBABLE CAUSE															
	ENGINE				PUMP						SYSTEM					
	A	B	C	D	E	F	G	H	I	J	K	L	M	N	O	P
No water delivered					X	X	X				X	X	X			X
Not enough water delivered	X						X	X			X	X	X			X
Not enough pressure	X						X	X			X	X	X			
Engine heats excessively		X	X					X	X	X		X		X		
Abnormal noise and/or vibration				X	X		X			X		X	X	X		
Pump works for a while, then stops				X			X			X			X		X	X

CAUSE	CORRECTIVE ACTION
1. ENGINE	
A. Speed too low.	Refer to engine section.
B. Rotating and/or reciprocating parts drag.	Refer to engine section.
C. Speed too high.	Maximum engine speed not to exceed engine manufacturer's recommendation.
D. Loose or broken parts.	Refer to engine section.
2. PUMP	
E. Not primed.	Reprime, inspect suction system for air leaks, and/or check assembly.
F. Pump takes too long to prime.	Check for air leaks or defective check valve.
G. Flow through pump completely or partially blocked.	Locate and remove obstruction. Attach strainer.
H. Internal leakage.	Check clearances between face of vanes and case. Should not exceed 1/32".
I. Rotating parts drag.	Inspect. Repair.
J. Loose or broken parts.	Inspect. Repair.
3. SYSTEM	
K. Pressure required by system at design flow rate exceeds pressure rating of pump.	Compare pump pressure and flow rate against pump performance chart. Reduce system pressure requirement. Increase pressure capability of pump.
L. Obstruction in suction piping.	Locate and remove obstruction. Attach strainer.
M. Suction lift too high.	Check with gauge or measure vertical distance between water surface and center line of pump, allowing for friction loss in suction pipe. Reduce rate of flow to obtain desired lift. Refer to pump performance chart.
N. Discharge head too low.	Decrease rate of flow.
O. Suction inlet not immersed deep enough.	Refer to "Installation" on page 2.
P. Leaky suction line or connection admitting air.	Repair or replace suction line. Tighten connections.

Pump Engine Operation and Maintenance

Engine Safety Precautions:

⚠️ WARNING **Fire and explosion hazard.** Gasoline can explode. Store gasoline away from the engine. Add gasoline to the engine only when the engine is off.

⚠️ WARNING **Burn hazard.** Hot surface. The engine gets very hot during operation. Do not touch the engine surfaces. Keep children away. Allow the engine to cool before moving it indoors.

⚠️ WARNING **Deadly fumes.** Carbon monoxide. Never run the engine in an enclosed space. Only use outdoors with plenty of ventilation.

Note: For detailed PowerPro engine information, consult engine manual (Form L-1512).

Engine Operation

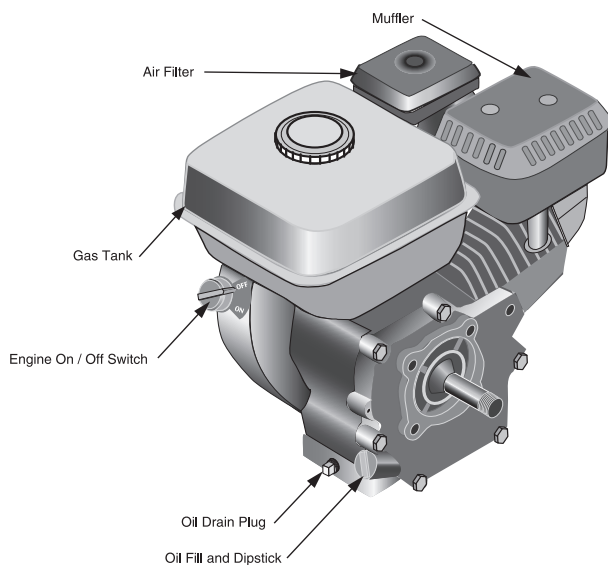

Before starting the engine:

Check and Fill Oil

⚠️ WARNING The engine is shipped **without oil**. It must be filled before starting the engine.

Fill with oil by removing the fill cap / dipstick. Add oil until the level reaches the bottom of the opening. Check the oil level by pushing the cleaned dipstick into the oil-fill opening. **DO NOT SCREW IT IN.** Remove the dipstick and inspect it. Add oil if needed. Reinstall the cap / dipstick.

Note that the engine has a low-oil monitoring system. If the oil level drops too low, the system will automatically turn off the engine.

Add Gasoline

Fill gas tank with clean, fresh gasoline. This should be unleaded fuel that has an octane rating of 86 or higher.

Do not fill the tank to overflowing. Clean up any spilled gasoline before starting the engine.

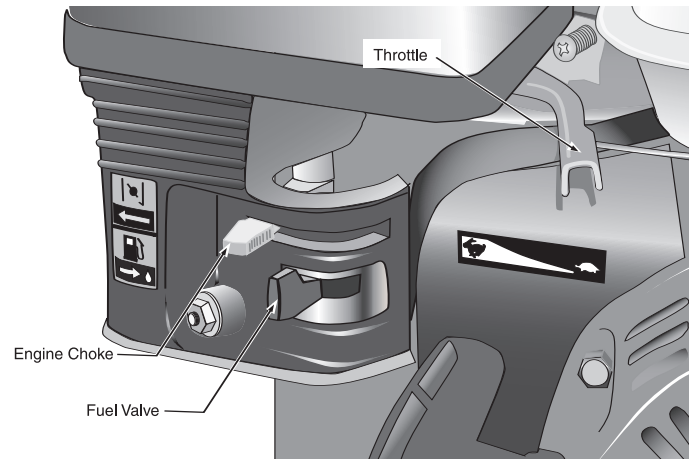

Open Fuel Valve

Move the fuel valve to the right to allow fuel to the engine.

Close Choke

When starting a cold engine, move the choke control to the left (closed). As the engine warms up, move it towards the right (open). A warm engine should start with the choke open.

Position Throttle

Move the throttle (speed control) slightly to the left.

Turn Engine Switch On

The engine switch controls the ignition. Turn it to the "ON" position to start the engine. The same control is used to stop the engine.

Pull Starter

Pull the handle on the recoil starter. Adjust throttle to desired speed. Move the choke to the right as engine warms.

Stopping the Engine

Stop the engine by turning the engine switch to "OFF."

Move the fuel valve to "OFF" (left).

Service Instructions

Engine Maintenance

Air Filter

The air filter should be checked every month for dust and dirt accumulation. Every 6 months, the filter element should be removed and cleaned. Clean the foam element with detergent and warm water. Squeeze out excess water and let it dry. Before reinstalling the filter element, soak it with engine oil and squeeze out the excess. Reinstall the filter. The engine will smoke upon start-up if too much oil is left in the filter element.

Oil Level

The oil level should be checked before each use.

Oil Change

The oil should be changed in the first month, and then every 6 months (or 100 hours of operation). To drain the oil, run the engine until warm. Turn off the engine, remove the oil drain plug, and let the the oil drain into a pan. Reinstall the plug and fill with oil. (Capacity: 20 ounces.)

Note: Dispose of used oil responsibly. DO NOT pour it down drains, onto the ground or put it in the trash. Most communities have collection points for used oil.

Spark Plug

The spark plug should be checked and cleaned every 6 months or 100 hours.

The spark plug should be replaced if it is damaged or excessively worn.

Engine Troubleshooting

If the engine won't start:

- Check that there is gas in the tank.
- Make sure the fuel valve is "ON" and that the engine switch is "ON."
- Make sure there is enough oil in the engine to reset the low-oil sensor.
- Check that fuel is getting to the carburetor.*
- Check for spark at the spark plug.*

* These checks to be done by persons with small-engine experience.

Extended Storage

If the pump will be stored for more than a month or two, follow the steps below:

- drain gasoline.
- change oil.
- squirt oil (or a chemical made for storing engines) in the spark plug hole.
- rotate engine slowly until resistance is felt. (This indicates that both valves are closed.)
- install spark plug.
- cover engine.

Performance Information

2" & 3" Gas Engine Drive, Pedestal Pump, Pump only for Gas Engines

2" Cast Iron Transfer Pumps: 3450 RPM

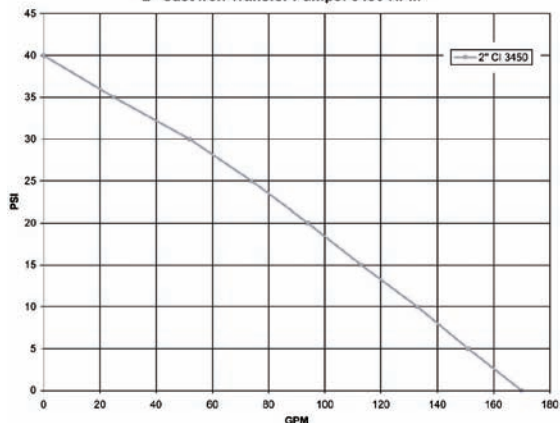

1533C-13ESP, 1533C-13SP, 1533C-9SP

English Standard

GPM at 0 PSI	GPM at 5 PSI	GPM at 10 PSI	GPM at 15 PSI	GPM at 20 PSI	GPM at 25 PSI	GPM at 30 PSI	GPM at 35 PSI	GPM at 40 PSI	GPM at 45 PSI	GPM at 50 PSI	GPM at 60 PSI	GPM at 66 PSI
330	325	321	315	296	273	248	221	192	161	129	48	0

9733C-SPX

English Standard

GPM at 0 PSI	GPM at 5 PSI	GPM at 10 PSI	GPM at 15 PSI	GPM at 20 PSI	GPM at 25 PSI	GPM at 30 PSI	GPM at 35 PSI	GPM at 40 PSI	GPM at 45 PSI	GPM at 50 PSI	GPM at 55 PSI	GPM at 60 PSI	GPM at 61 PSI
330	325	320	310	290	265	230	195	163	133	95	50	11	0

3" Cast Iron Transfer Pumps: 3450 RPM

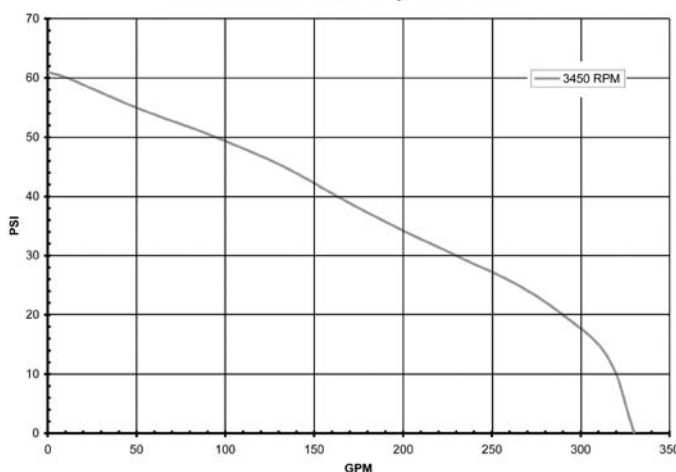

9732C-SPX

English Standard

GPM at 0 PSI	GPM at 5 PSI	GPM at 10 PSI	GPM at 15 PSI	GPM at 20 PSI	GPM at 25 PSI	GPM at 30 PSI	GPM at 35 PSI	GPM at 40 PSI
170	151	133	113	94	74	52	25	0

1532C-6SP, 9232C-SP, 3430-0673CSP

English Standard

GPM at 0 PSI	GPM at 5 PSI	GPM at 10 PSI	GPM at 15 PSI	GPM at 20 PSI	GPM at 25 PSI	GPM at 30 PSI	GPM at 35 PSI	GPM at 40 PSI	GPM at 42 PSI
170	155	140	123	106	87	65	42	14	0

2" Hydraulic Motor Drive

Hyd Pump 2" HM1C

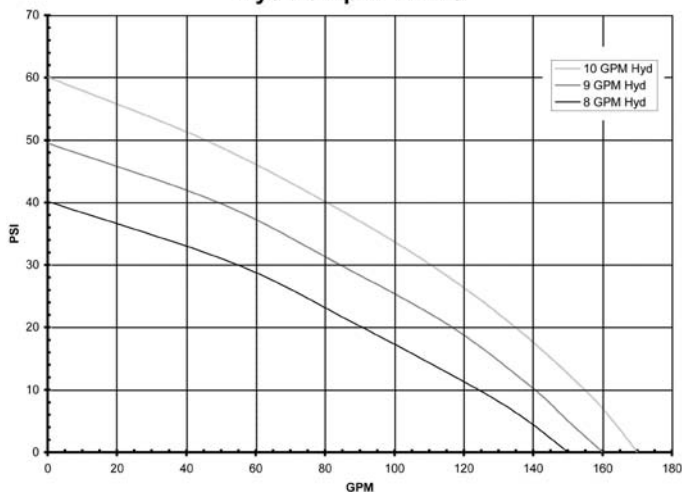

Hyd Pump 2" HM5C

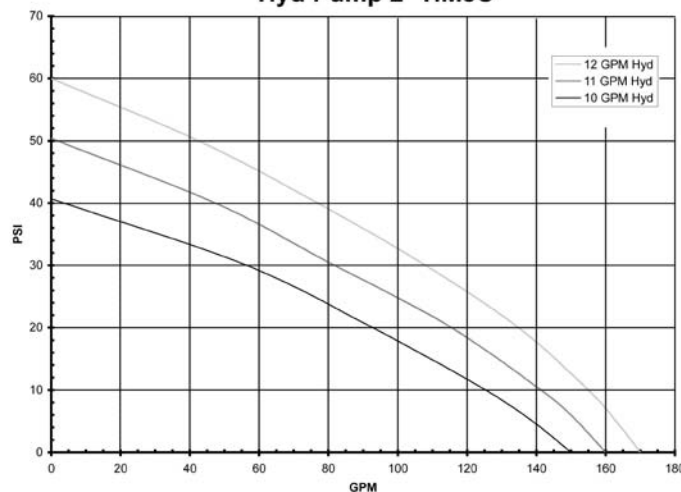

9332C-HM1C-SP

English Standard

Hyd. Flow GPM	GPM at 0 PSI	GPM at 5 PSI	GPM at 10 PSI	GPM at 20 PSI	GPM at 30 PSI	GPM at 40 PSI	GPM at 50 PSI	GPM at 60 PSI
10	170	163	155	135	108	77	42	0
9	160	150	140	113	79	48	0	
8	150	138	124	88	53	0		

9332C-HM5C-SP

English Standard

Hyd. Flow GPM	GPM at 0 PSI	GPM at 5 PSI	GPM at 10 PSI	GPM at 20 PSI	GPM at 30 PSI	GPM at 40 PSI	GPM at 50 PSI	GPM at 60 PSI
12	170	163	155	135	108	77	42	0
11	160	150	140	113	79	48	0	
10	150	138	123	90	55	0		

9232C-SP and 9732C-SPX Self-Priming Cast Iron Centrifugal Pumps

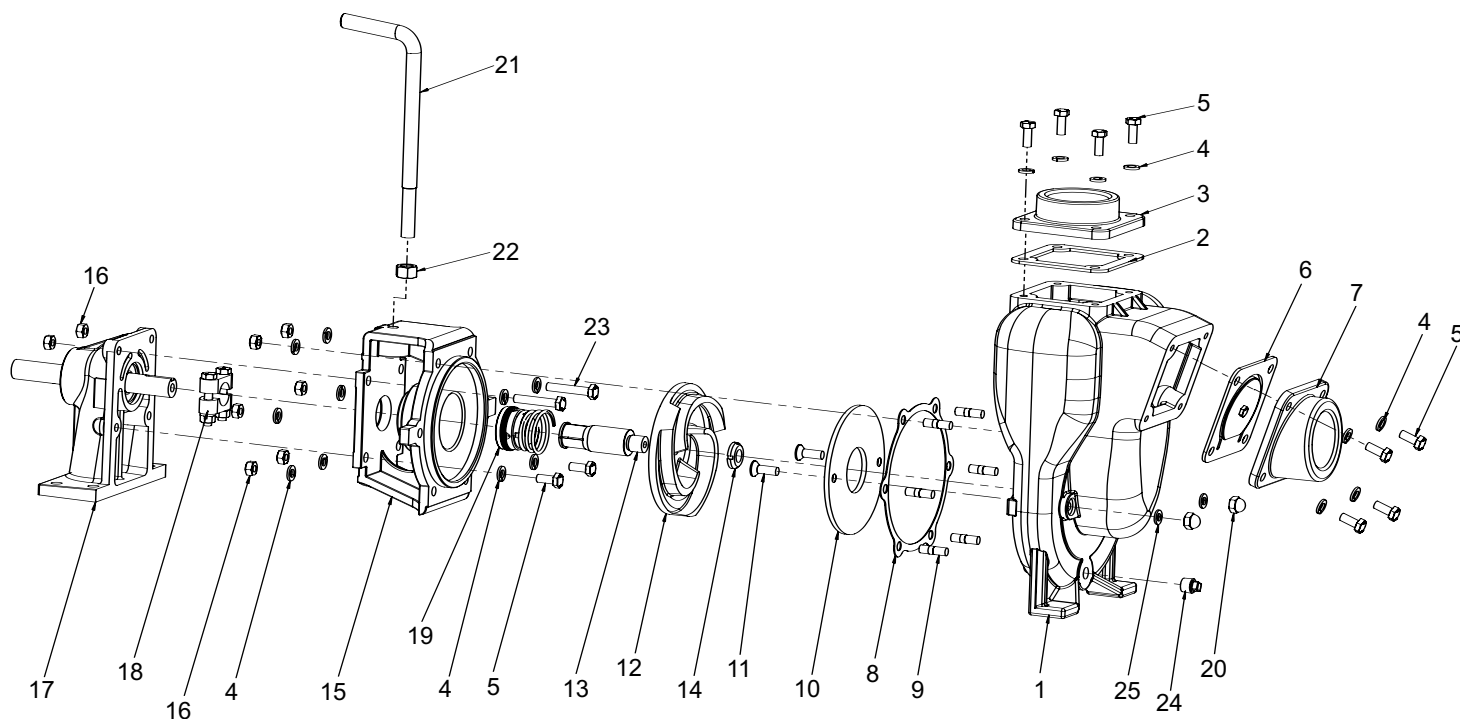

REF. NO.	QTY.	PART NO.	DESCRIPTION
1	1	0150-9032C	Self-Priming Chamber
2	1	1700-0217	Discharge Flange Gasket (EPDM)
3	1	2404-0362	Discharge Flange (2" NPT)
4	18	2260-0051	Lockwasher
5	10	2210-0160	Cap Screw
6	1	1700-0218	Flapper Valve Assembly (EPDM)
7	1	2404-0363	Inlet Flange (2" NPT)
8	1	1710-0017	Gasket
9	6	2205-0021	Stud
10	1	3210-0094	Wear Plate
11	2	2215-0004	Screw
12	1	0400-9032C	Impeller
13	1	0501-9032	Shaft Sleeve (3/4")

REF. NO.	QTY.	PART NO.	DESCRIPTION
14	1	2250-0095	Impeller Nut
15	1	0750-9032C	Mounting Flange (Gas Engine)
16	8	2250-0094	Hex Nut
17	1	0550-9232	Pedestal Assembly (3/4")
18	1	1420-0023	Shaft Sleeve Clamp
19	1	2120-0046	Mechanical Seal (FKM)
20	2	2253-0012	Acom Nut 5/16-18 SS
21	1	2801-0007	Handle
22	1	2250-0093	Hex Nut
23	2	2210-0159	Cap Screw
24	1	2406-0041	External Square Drain Plug (1/4" NPT)
25	2	1700-0021	Gasket

9233C-SP and 9733C-SPX Self-Priming Cast Iron Centrifugal Pumps

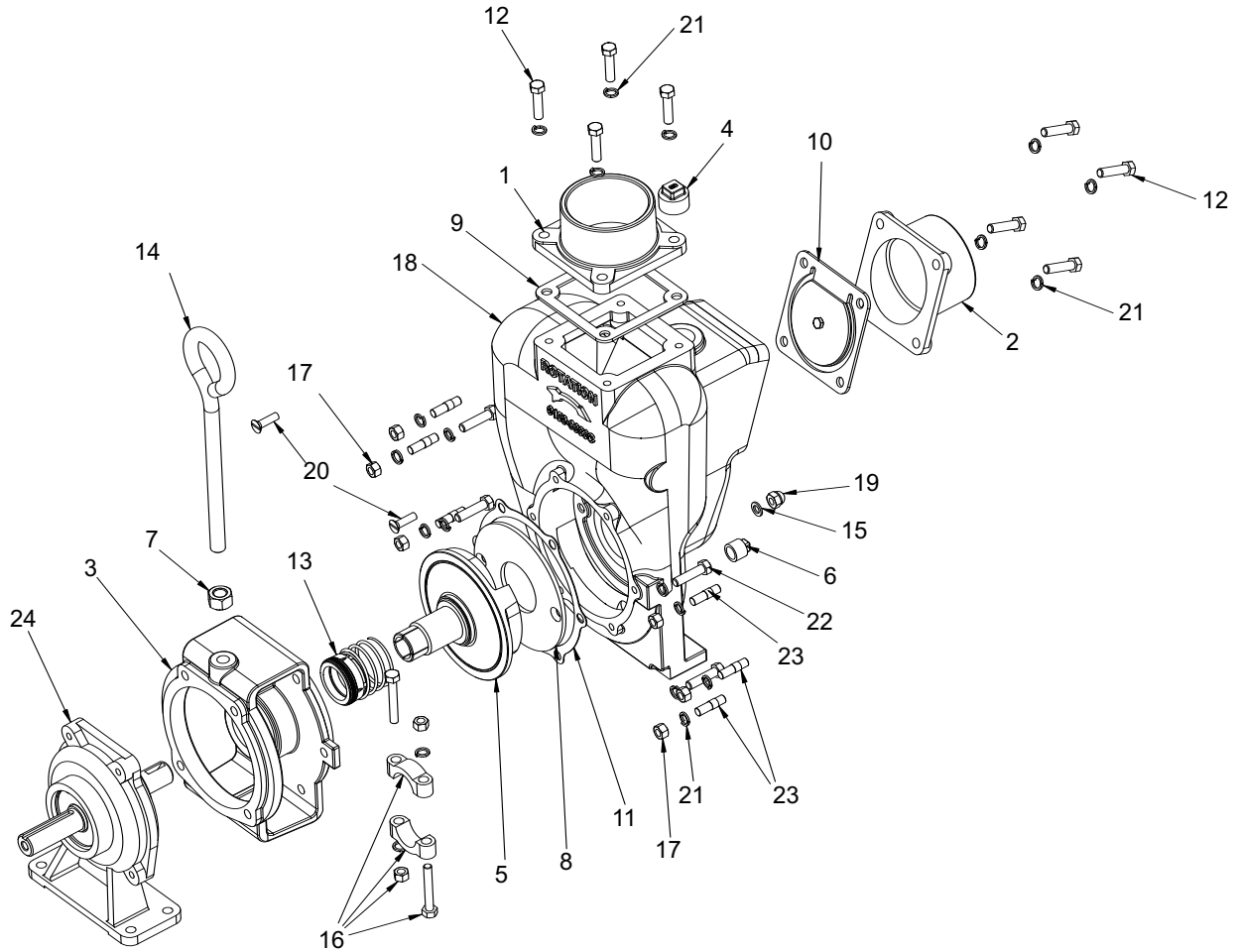

REF. NO.	QTY.	PART NO.	DESCRIPTION
1	1	2404-0361	Discharge Flange (3" NPT)
2	1	2404-0364	Inlet Flange (3" NPT)
3	1	0750-9033C	Mounting Flange (Gas Engine)
3	1	0750-9733C	Mounting Flange (NEMA C)
4	1	2406-0042	Fill Plug (1" NPT)
5	1	0400-9033C	Impeller w/shaft (1")
5	1	0400-9733C	Impeller w/shaft (1-3/8")
6	1	2406-0043	Drain Plug (1/2" NPT)
7	1	2250-0096	Nut 5/8-11 Zinc
8	1	3210-0095	Wear Plate
9	1	1700-0219	Discharge Flange Gasket (EPDM)
10	1	1700-0220	Flapper Valve Assembly (EPDM)
11	1	1710-0018	Gasket
12	8	2210-0161	Cap Screw Hex Head 3/8-16 x 1-1/8" Zinc
13	1	2120-0047	Mechanical Seal (FKM)

REF. NO.	QTY.	PART NO.	DESCRIPTION
14	1	2801-0008	Handle
15	2	1700-0221	Washer (Plastic)
16	1	1420-0024	Shaft Sleeve Clamp Assy. (1")
16	1	1420-0026	Shaft Sleeve Clamp Assy. (1.375")
17	6	2250-0097	Nut 3/8-24 SS
18	1	0150-9033C	Self Priming Chamber
19	2	2253-0011	Acorn Nut 3/8-16 SS
20	2	2215-0005	Screw Slotted Flat Head 3/8-16 x 1" SS
21	18	2260-0052	Lockwasher 3/8 Zinc
22	4	2210-0163	Cap Screw Hex Head 3/8-16 x 2-1/2" Zinc Gr 5
23	6	2205-0022	Stud 3/8-24
24	1	0550-9233	Pedestal Assembly (1")
N/S	1 pr.	1520-0099	Mounting Rails-zinc plated (std. on gas engine models; optional on other models)

Limited Warranty on Hypro Pumps and Other Hypro Products

Hypro warrants to the original purchaser of its products (the "Purchaser") that such products will be free from defects in material and workmanship under normal use for the period of one (1) year for all products except: oil crankcase plunger pumps will be free from defects in material and workmanship under normal use for the period of five (5) years, and accessories will be free from defects in material and workmanship under normal use for the period of ninety (90) days. In addition, Hypro warrants to the purchaser all forged brass pump manifolds will be free from defects in material and workmanship under normal use and from damage resulting from environmental conditions for the life of the pump.

"Normal use" does not include use in excess of recommended maximum speeds, pressures, vacuums and temperatures, or use requiring handling of fluids not compatible with component materials, as noted in Hypro product catalogs, technical literature, and instructions. This warranty does not cover freight damage, freezing damage, normal wear and tear, or damage caused by misapplication, fault, negligence, alterations, or repair that affects the performance or reliability of the product.

THIS WARRANTY IS EXCLUSIVE. HYPRO MAKES NO OTHER WARRANTY, EXPRESS OR IMPLIED, INCLUDING BUT NOT LIMITED TO ANY WARRANTY OF MERCHANTABILITY OR FITNESS FOR A PARTICULAR PURPOSE.

Hypro's obligation under this warranty is, at Hypro's option, to either repair or replace the product upon return of the entire product to the Hypro factory in accordance with the return procedures set forth below. **THIS IS THE EXCLUSIVE REMEDY FOR ANY BREACH OF WARRANTY.**

IN NO EVENT SHALL HYPRO BE LIABLE FOR ANY INCIDENTAL OR CONSEQUENTIAL DAMAGES OF ANY KIND, WHETHER FOR BREACH OF ANY WARRANTY, FOR NEGLIGENCE, ON THE BASIS OF STRICT LIABILITY, OR OTHERWISE.

Return Procedures

All pumps or products must be flushed of any chemical (ref. OSHA Section 0910.1200 (d)(e)(f)(g)(h) and hazardous chemicals must be labeled before being shipped* to Hypro for service or warranty consideration. Hypro reserves the right to request a Material Safety Data sheet from the Purchaser for any pump or product Hypro deems necessary. Hypro reserves the right to "disposition as scrap" pumps or products returned which contain unknown substances, or to charge for any and all costs incurred for chemical testing and proper disposal of components containing unknown substances. Hypro requests this in order to protect the environment and personnel from the hazards of handling unknown substances.

For technical or application assistance, call the **Hypro Technical/Application number: 1-800-445-8360. To obtain service or warranty assistance, call the Hypro Service and Warranty number: 1-800-468-3428; or call the Hypro Service and Warranty FAX: (651) 766-6618.**

Be prepared to give Hypro full details of the problem, including the following information:

1. Model number and the date and from whom you purchased your pump.
2. A brief description of the pump problem, including the following:
 - Liquid pumped. State the pH and any non-soluble materials, and give the generic or trade name.
 - Temperature of the liquid and ambient environment.
 - Suction lift or vacuum (measured at the pump).
 - Discharge pressure.
 - Size, type, and mesh of the suction strainer.
 - Drive type (gas engine/electric motor; direct/belt drive; tractor PTO) and rpm of pump.
 - Viscosity (of oil, or other than water weight liquid).
 - Elevation from the pump to the discharge point.
 - Size and material of suction and discharge line.
 - Type of spray gun, orifice size, unloader/relief valve.

Hypro may request additional information and may require a sketch to illustrate the problem.

Contact the factory to receive a return material authorization before sending the product. All pumps returned for warranty work should be sent shipping charges prepaid to:

Hypro
Attention: Service Department
375 Fifth Avenue NW
New Brighton, Minnesota 55112

*Carriers, including U.S.P.S., airlines, UPS, ground freight, etc., require specific identification of any hazardous materials being shipped. Failure to do so may result in a substantial fine and/or prison term. Check with your shipping company for specific instructions.



HYPRO®

**Pentair Water
SPRAY GROUP**

375 Fifth Avenue NW • New Brighton, MN 55112
Phone: (651) 766-6300 • 800-424-9776 • Fax: 800-323-6496
www.hypropumps.com