



## General Safety Information

### NOTE

Notes are used to notify of installation, operation, or maintenance information that is important but not safety related.

### CAUTION

Caution is used to indicate the presence of a hazard, which will or may cause minor injury or property damage if the notice is ignored.

### WARNING

Warning denotes that a potential hazard exists and indicates procedures that must be followed exactly to either eliminate or reduce the hazard, and to avoid serious personal injury, or prevent future safety problems with the product.

### DANGER

Danger is used to indicate the presence of a hazard that will result in severe personal injury, death, or property damage if the notice is ignored.

### DANGER

Do not pump flammable or explosive fluids such as gasoline, fuel oil, kerosene, etc. Do not use in explosive atmospheres. The pump should only be used with liquids compatible with the pump materials. Failure to follow this notice may result in severe personal injury and/or property damage and will void the product warranty.

### WARNING

The sound pressure level of the pump may exceed 80dBA. Observe all safety precautions when operating the pump within close proximity for extended periods by wearing hearing protectors. Extended exposure to elevated sound levels will result in permanent loss of hearing acuteness, tinnitus, tiredness, stress, and other effects such as loss of balance and awareness.

### CAUTION

- Do not pump at pressures higher than the maximum recommended pressure.
- Operate the pump between a temperature range of 45° to 140° F [7° to 60° C].
- Make certain that the power source conforms to the requirements of your equipment.

- Provide adequate protection in guarding around the moving parts such as shafts and pulleys.
- Disconnect the power before servicing.
- Release all pressure within the system before servicing any component.
- Drain all liquids from the system before servicing.
- Secure the discharge line before starting the pump. An unsecured discharge line may whip, resulting in personal injury and/or property damage.
- Check all hoses for weak or worn condition before each use. Make certain that all connections are tight and secure.
- Periodically inspect the pump and the system components. Perform routine maintenance as required (See Maintenance).
- Use only pipe, hose, and hose fittings rated for maximum rated pressure of the pump or the pressure at which the pressure relief valve is set at. Do not use used pipe.
- Do not use these pumps for pumping water or other liquids for human or animal consumption.

## Hazardous Substance Alert

1. Always drain and flush pump before servicing or disassembling for any reason (see instructions).
2. Always drain and flush pump prior to returning unit for repair.
3. Never store pumps containing hazardous chemicals.
4. Before returning pump for service/repair, drain out all liquids and flush unit with neutralizing liquid. Then, drain the pump. Attach tag or include written notice certifying that this has been done.

### NOTE

It is illegal to ship or transport any hazardous chemicals without United States Environmental Protection Agency Licensing.

## Plumbing Installation

### Mount self-priming adaptor in a secure location.

Optional bracket kit available, PN 3430-0700.

**Max. SPA Height:** Top of SPA no higher than bottom of fill port.

**Min. SPA Height:** Top of SPA mounted higher than top of casting on inlet port to support gravity feed system.

**Max. Hose Distance:** Hose length between SPA and pump inlet should be no more than three meters (10 ft.).

**Vent Line minimum diameter:** 25mm (1 in.) diameter raised a 1/2 meter (20 in.) above SPA before entering tank. Use clear hose if possible as indicator for priming.

**Return Line:** Return line is subject to suction vacuum pressure. Use hose rated for vacuum pressure of discharge -75 cm (-30 inches) Hg.

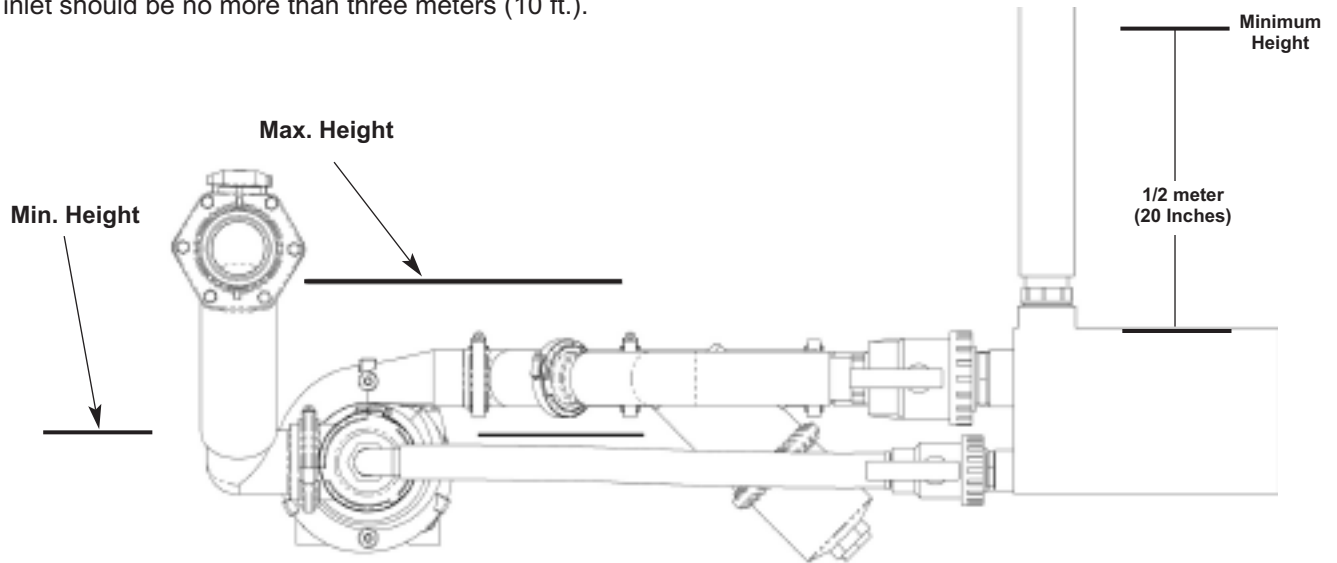

Mount self-priming adaptor in a location within 3 meters (10 ft.) of the pump inlet. The self-priming adaptor chamber is rated as a low pressure tank and is not designed to accept pressures over 3 Bar (45 PSI). System should be plumbed to protect from over-pressurization.

Use of two-way and/or three-way valves can be used to direct flow through the self-priming adaptor (SPA) during priming operation. The vent line can be sized to be used to

fill the tank once the pump has primed. Use 32 mm (1-1/4 in.) max ID vacuum hose for return line from the SPA to the pump inlet port. Directing circulation flow from SPA directly towards pump inlet impeller eye will greatly increase overall priming performance and stability.

The return line from the SPA to the pump inlet must be hose rated for vacuum pressure.

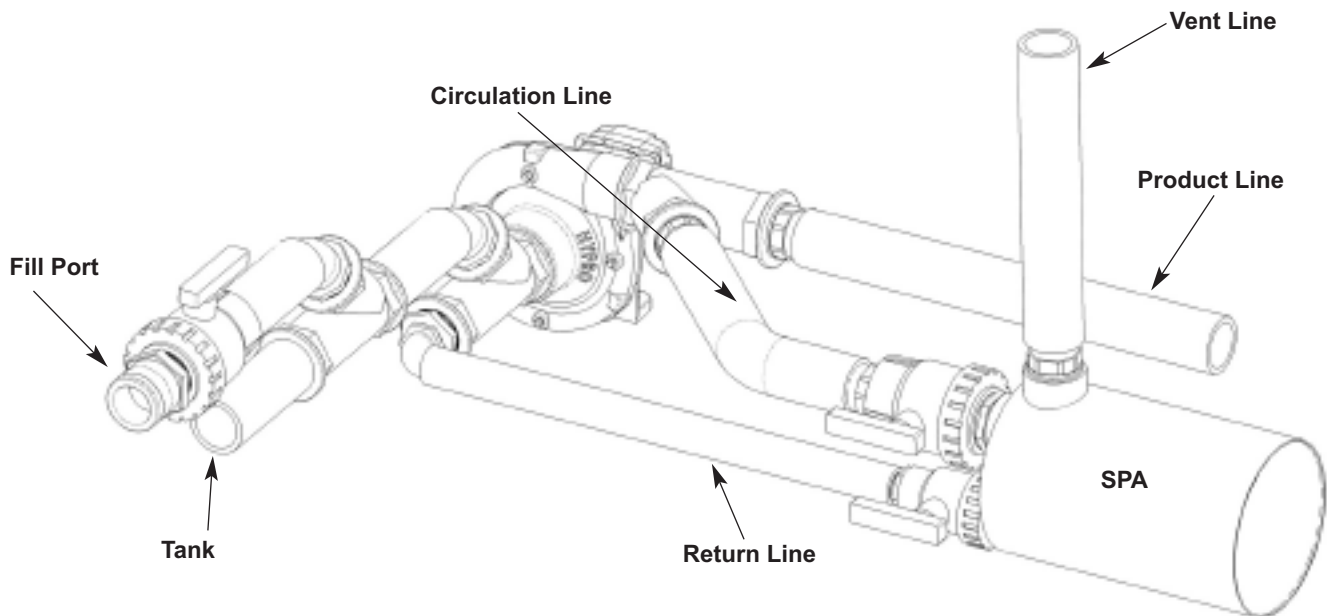

# Plumbing Installation

## MANIFOLD SYSTEMS PLUMBING

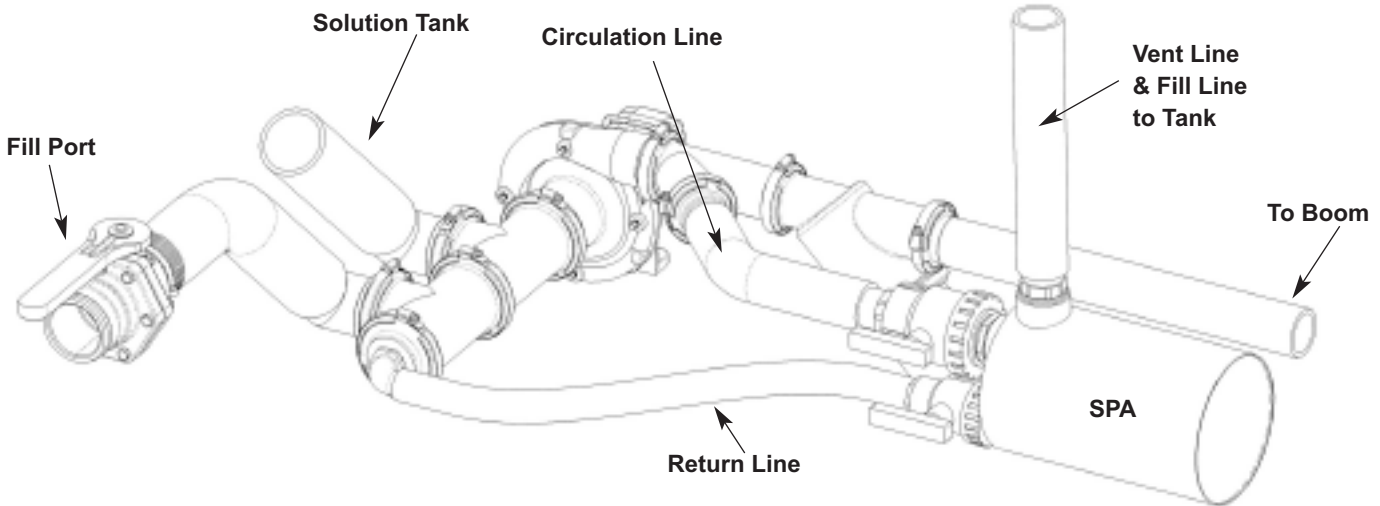

Manifold systems will function well with SPA. It is important to direct the return line from the SPA to the pump inlet in a manner as to jet the flow into the pump impeller to ensure good priming performance and stability. Use of Y fittings at the inlet of the pump will aid in accomplishing a positive

flow towards pump impeller. To ensure that the fluid necessary to induce priming does not cascade out of the system, be sure that all other systems are turned off during priming (boom, agitation, chemical education).

## Operation and Maintenance

To facilitate pump priming, water or fluid is circulated through eye of the impeller and pump. The attached SPA allows for entrained air to percolate out of the liquid being circulated and releases the air back to atmosphere through the vent line. The liquid is returned back to the pump inlet, thereby evacuating the inlet suction line of air. Once the pump is primed, pressure increases in the separation chamber. The operator then closes off the circulation path to the pump inlet and SPA and redirects the pump flow to fill sprayer tank.

The vent line can also be used to complete the circuit for filling the sprayer tank. In many systems, the vent line provides an efficient path to the tank and greatly decreases the amount of time to fill the tank. If the vent line is used to fill the tank, the return line is shut off once the inlet fill line is primed. To operate the pump in spray mode, close off self-priming circuit and fill line, then open tank valve.

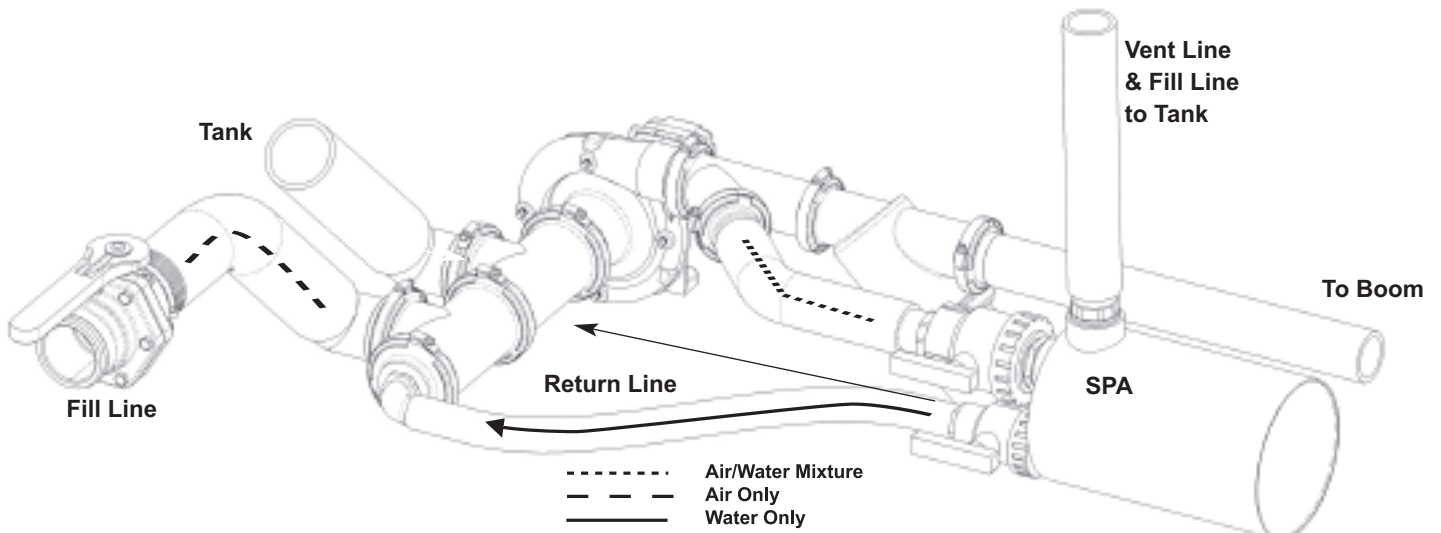

## Operation and Maintenance

A simple way to test the system is to insert a vacuum gauge on the fill port to measure the amount of vacuum the pump is producing. When the pump is running, and water is being circulated through the SPA, a reading of -63 to -75 cm (-25 to -30 inches) of Hg vacuum pressure is expected. Simply placing your hand over the inlet port will also give a good indication of operation.

Pump speed can also increase priming rates. Speed of pump should operate in the range of 3500 to 5000 RPMs to get good results.

Having a clear vent line and return line hose can be a good indicator for how the SPA is working and when priming is achieved. Simply listening to the pump operation will also indicate when priming has occurred; a sudden change in RPM is associated with pump flow when the pump is primed.



## Troubleshooting Guide

Symptom	Probable Cause(s)	Corrective Action
Pump fails to prime.	No liquid or low liquid level for water circulation to induce priming.	Open clean water tank valve to fill priming circuit with adequate water to operate priming circuit. Water will flow out vent line or fill port if filled to an adequate level.
	Valves are not open to provide path for water circulation through priming system.	Check valves to make sure they are in correct position for priming.
	Vacuum leaks.	Check that valve to tank is closed and valve on fill line is open.
	Pump operating speed too low.	Increase pump speed (4000 to 5000 RPM).
Surging during priming.	Low liquid level in SPA.	Crack open clean water tank to fill tank and priming circuit to acceptable liquid level.
	Too much air is returning with liquid to pump short-circuiting priming.	Reduce liquid flow back to pump by reducing return line by one size ID.
	Pump operating speed too high.	Reduce pump speed during priming.
Vacuum decreases over time during priming operation.	Water for priming is initially adequate but cascades away from priming circuit.	Check to make sure water is not finding another discharge path, such as agitation or to boom.

# Dimensions

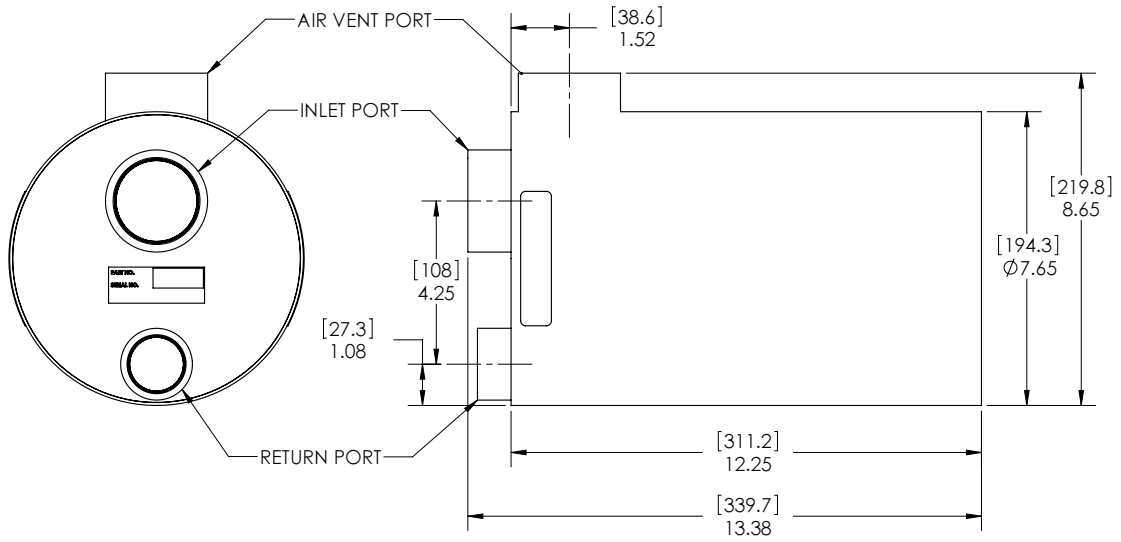

**Self-Priming Adaptor  
1530-0024S**

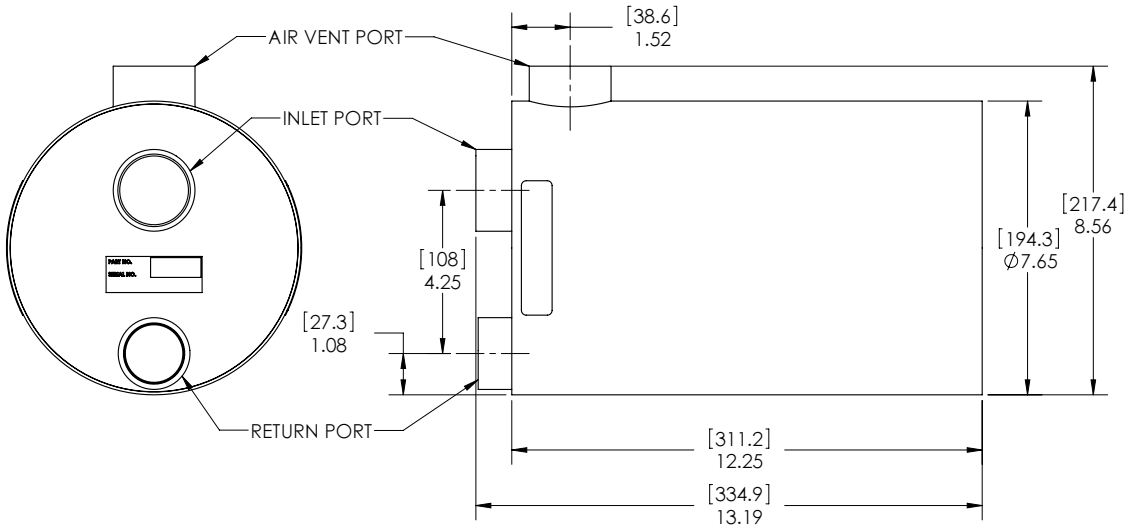

**Self-Priming Adaptor  
1530-0025S**

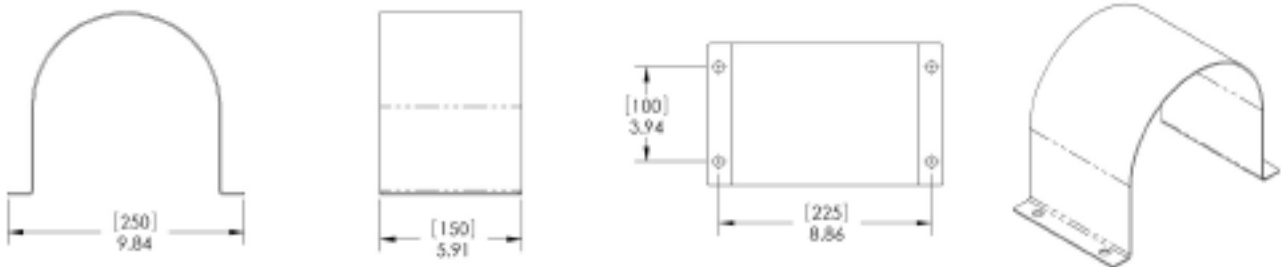

**Mounting Bracket Kit  
3430-0700  
(Bracket Only Shown 1520-0102)**

# Performance

### Pump Self-Priming Performance With Self-Priming Adaptor

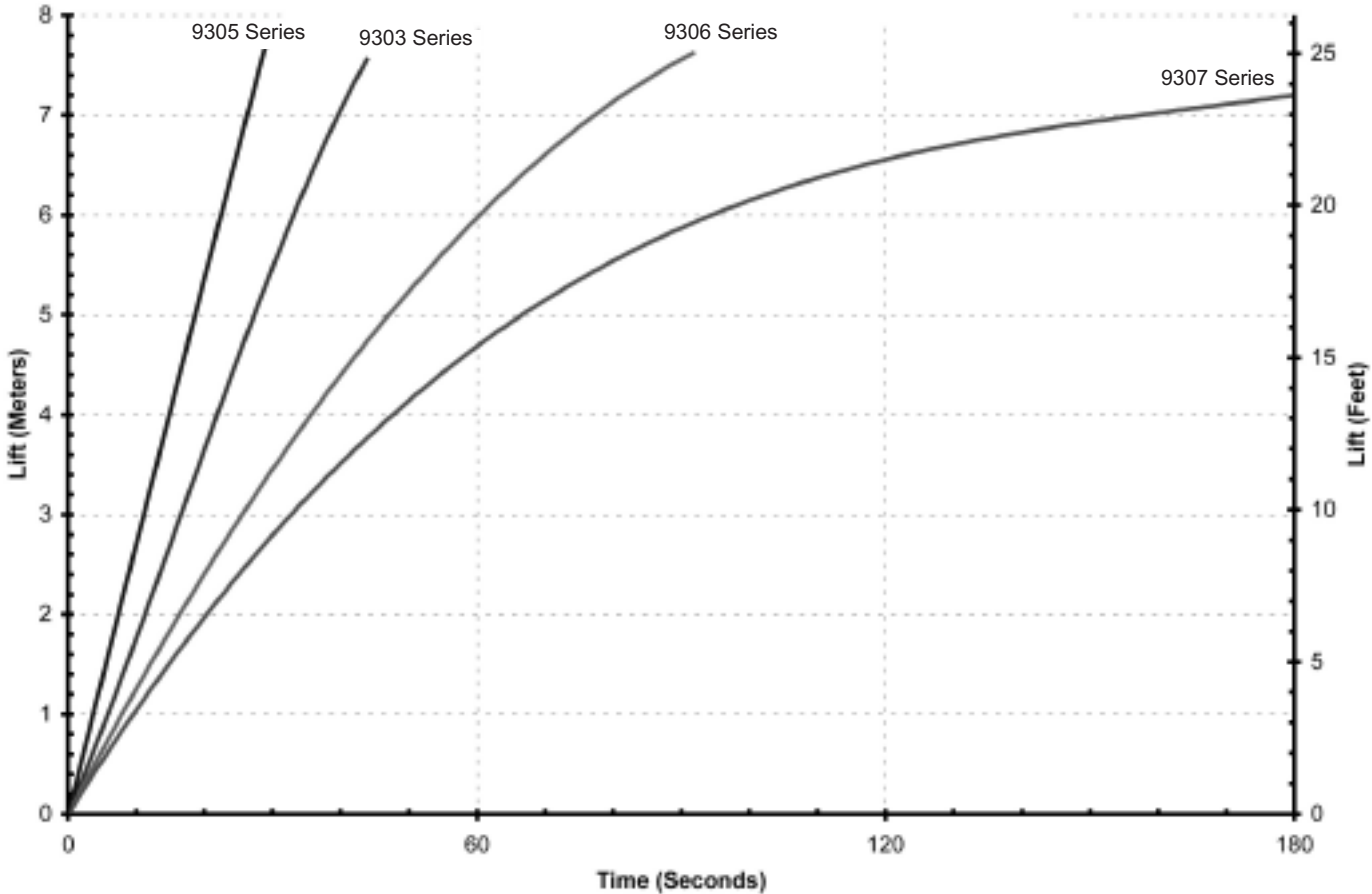

Priming rates are dependent on optimal plumbing systems, length and size of inlet hose, and rotational speed of pump impeller. Actual rates may vary depending on system configuration.

Comparison test results were produced in lab under controlled environment. Total lift capacity of pumps is expected to be 7.6 meters (25 feet) or more.

Because pump is moving water, the system is able to develop 1.7 bar (25 PSI) pressure against any restriction in vent line during priming at no lift and .34 bar (5 PSI) pressure at 7 meters (23 feet) of lift.

## Limited Warranty on Hypro Pumps and Other Hypro Products

Hypro warrants to the original purchaser of its self-priming adaptor will be free from defects in material and workmanship under normal use for the period of one (1) year.

“Normal use” does not include use in excess of recommended maximum speeds, pressures, vacuums and temperatures, or use requiring handling of fluids not compatible with component materials, as noted in Hypro product catalogs, technical literature, and instructions. This warranty does not cover freight damage, freezing damage, normal wear and tear, or damage caused by misapplication, fault, negligence, alterations, or repair that affects the performance or reliability of the product.

**THIS WARRANTY IS EXCLUSIVE. HYPRO MAKES NO OTHER WARRANTY, EXPRESS OR IMPLIED, INCLUDING BUT NOT LIMITED TO ANY WARRANTY OF MERCHANTABILITY OR FITNESS FOR A PARTICULAR PURPOSE.**

Hypro's obligation under this warranty is, at Hypro's option, to either repair or replace the product upon return of the entire product to the Hypro factory in accordance with the return procedures set forth below. **THIS IS THE EXCLUSIVE REMEDY FOR ANY BREACH OF WARRANTY.**

**IN NO EVENT SHALL HYPRO BE LIABLE FOR ANY INCIDENTAL OR CONSEQUENTIAL DAMAGES OF ANY KIND, WHETHER FOR BREACH OF ANY WARRANTY, FOR NEGLIGENCE, ON THE BASIS OF STRICT LIABILITY, OR OTHERWISE.**

### Return Procedures

**All pumps or products must be flushed of any chemical (ref. OSHA Section 0910.1200 (d)(e)(f)(g)(h) and hazardous chemicals must be labeled before being shipped\* to Hypro for service or warranty consideration.** Hypro reserves the right to request a Material Safety Data sheet from the Purchaser for any pump or product Hypro deems necessary. Hypro reserves the right to “disposition as scrap” pumps or products returned which contain unknown substances, or to charge for any and all costs incurred for chemical testing and proper disposal of components containing unknown substances. Hypro requests this in order to protect the environment and personnel from the hazards of handling unknown substances.

For technical or application assistance, call the **Hypro Technical/Application number: 1-800-445-8360.**

**To obtain service or warranty assistance, call the Hypro Service and Warranty number: 1-800-468-3428;**

**or call the Hypro Service and Warranty FAX: (651) 766-6618.**

Be prepared to give Hypro full details of the problem, including the following information:

1. Model number and the date and from whom you purchased your pump.
2. A brief description of the pump problem, including the following:
  - Liquid pumped. State the pH and any non-soluble materials, and give the generic or trade name.
  - Temperature of the liquid and ambient environment.
  - Suction lift or vacuum (measured at the pump).
  - Discharge pressure.
  - Size, type, and mesh of the suction strainer.
  - Drive type (gas engine/electric motor; direct/belt drive; tractor PTO) and rpm of pump.
  - Viscosity (of oil, or other than water weight liquid).
  - Elevation from the pump to the discharge point.
  - Size and material of suction and discharge line.
  - Type of spray gun, orifice size, unloader/relief valve.

Hypro may request additional information and may require a sketch to illustrate the problem. Contact the factory to receive a return material authorization before sending the product. All pumps returned for warranty work should be sent shipping charges prepaid to:

HYPRO  
Attention: Service Department  
375 Fifth Avenue NW  
New Brighton, Minnesota 55112

\* Carriers, including U.S.P.S., airlines, UPS, ground freight, etc., require specific identification of any hazardous materials being shipped. Failure to do so may result in a substantial fine and/or prison term. Check with your shipping company for specific instructions.



**HYPRO®**

**Pentair Water  
SPRAY GROUP**

375 Fifth Avenue NW • New Brighton, MN 55112  
Phone: (651) 766-6300 • 800-424-9776 • Fax: 800-323-6496  
[www.hypropumps.com](http://www.hypropumps.com)